

# Manuale uso e manutenzione

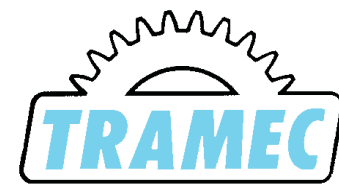

INDICE		INDEX	INHALTSVERZEICHNIS	Pag. Page Seite
1	AVVERTENZE GENERALI SULLA SICUREZZA	GENERAL SAFETY GUIDELINES	ALLGEMEINE SICHERHEITSHINWEISE	2
2	STATO DI FORNITURA	CONDITIONS OF SUPPLY	LIEFERBEDINGUNGEN	4
3	INSTALLAZIONE	INSTALLATION	INSTALLATION	7
4	LUBRIFICAZIONE	LUBRICATION	SCHMIERUNG	11
5	MESSA IN SERVIZIO / Rischi residui	STARTING-UP / Residual risks	INBETRIEBNAHME / Restgefahr	18
6	MANUTENZIONE	MAINTENANCE	INSTANDHALTUNG	19
7	LISTA PARTI DI RICAMBIO	SPARE PARTS LIST	ERSATZTEILLISTE	20
		TA/TF 56B - TA/TF 63B		20
		TA/TF 56C - TA/TF 63C		22
		TA..B - TC..B - TF..B		24
		TA..C - TC..C - TF..C		26
		TA..B - TC..B - TF..B - TA..C - TC..C - TF..C (Dispositivo antiritorno - <i>Backstop device</i> - Rücklaufsperr)		28
		ZA..A		30
		ZA..B - ZF..B		32
		ZA..C - ZF..C		34
		ZA..B - ZF..B - ZA..C - ZF..C (Dispositivo antiritorno - <i>Backstop device</i> - Rücklaufsperr)		36
		PA..A		38
		PA..B - PC..B		40
		PA..B (Dispositivo antiritorno - <i>Backstop device</i> - Rücklaufsperr)		42
		MA..B		44
		MA..B (Dispositivo antiritorno - <i>Backstop device</i> - Rücklaufsperr)		46
		RA - RC - RF (in = 1)		48
		RA - RC - RF (in > 1)		50
		RA - RC - RF (in = 1) s.e.		52
		RA - RC - RF (in > 1) s.e.		54
		XA - XF		56
		XC - KC		58
		HA - HF		62
		XXA - XXF		64
		XXC - KXC		64
		X.-H.-K.-XX.-KX.-KK. (Dispositivo limitatore di coppia - <i>Torque limiter device</i> - Rutschkupplungsvorrichtung)		66
8.0	Condizioni generali di garanzia	General conditional of warranty	Allgemeine garantiebedingungen	68

## 1.0 AVVERTENZE GENERALI SULLA SICUREZZA

I riduttori Tramec sono conformi alla direttiva macchine 2006/42 CE, sono identificati come quasi macchine (all-IIB). I riduttori saranno accompagnati da una dichiarazione di incorporazione. La lingua ufficiale delle istruzioni per l'uso, l'assemblaggio, la manutenzione è l'inglese. Divieto assoluto di usare i riduttori standard in ambienti esplosivi, solo ambienti non classificati.

Tutte le seguenti avvertenze sono riferite all'utilizzo di riduttori e motoriduttori, pertanto tutte le attività relative alla movimentazione, installazione, avviamento, manutenzione e riparazione debbono essere effettuate da personale qualificato (definito secondo IEC 364) che sia a conoscenza delle informazioni contenute nel presente manuale.

Eventuali componenti speciali saranno corredati di informazioni aggiuntive (da richiedere se non disponibili).

Si raccomanda inoltre di attenersi:

- a eventuali simboli inerenti la sicurezza indicati su etichette adesive sui riduttori e/o motori
- alle istruzioni relative all'impianto
- alle normative applicabili per una corretta installazione
- alle vigenti disposizioni legislative relative alla sicurezza

Tutti i riduttori e motoriduttori citati nel presente manuale sono destinati ad un impiego industriale con temperatura ambiente da -20°C a +40°C ad una altitudine max di 1000 m slm.

Per l'installazione di motori elettrici, motovariatori, inverter, ecc. attenersi alle disposizioni riportate nella relativa documentazione (da richiedere se non disponibile).

I dati tecnici e le informazioni relative alle condizioni di utilizzo dei riduttori e motoriduttori sono indicate sulle targhette e sui rispettivi cataloghi tecnici.

Se previsti impieghi diversi, il responsabile dell'installazione dovrà adottare e garantire eventuali protezioni supplementari che dovessero rendersi necessarie.

Non è consentito l'impiego dei riduttori e motoriduttori standard in:

- ambienti salini
- atmosfere aggressive con pericolo di esplosione
- ambienti con elevata percentuale di umidità
- ambienti fluidi o in totale immersione

## 1.0 GENERAL SAFETY GUIDELINES

*Tramec gearboxes are in compliance with machinery directive 2006/42 EC and are identified as partly completed machinery (Annex II-B). Tramec gearboxes are supplied with a declaration of incorporation. The official language of the instructions for use, assembly and maintenance is english. It is absolutely forbidden to use standard gearboxes in explosive atmospheres. Standard gearboxes cannot be used in environments which are classified in the atex directive.*

*All given instructions refer to the use of reducers and gear motors, which must be handled, installed, started and serviced by qualified personnel (in compliance with standard IEC 364) who are fully familiar with the content of this manual.*

*Additional information, to be applied for if not available, shall be given for special parts.*

*Please also comply with:*

- *given safety symbols on reducer and/or motor labels*
- *system operating instructions*
- *applicable standards for installation*
- *current laws on safety*

*All reducers and gear motors mentioned in this manual are intended for industrial use and operation at a room temperature between -20°C and +40°C, at an altitude of max. 1000 m above sea level.*

*Please comply with the instructions given in the pertaining manuals when installing electric motors, variable speed motors, inverters, etc... Please apply for manuals if not available.*

*Technical data and information concerning operating conditions of reducers and gearmotors are reported on identification plates and in technical catalogues.*

*In case of different uses, the chief installer shall take all necessary additional measures to ensure safe operating conditions.*

*Standard reducers and gear motors cannot be operated in:*

- *salty environments*
- *inflammable environments or products*
- *highly humid environments*
- *in the presence of fluids or fully immersed*

## 1.0 ALLGEMEINE SICHERHEITSHINWEISE

Tramec getriebe entsprechen der richtlinie für maschinen 2006/42 EG und werden als unvollständige maschinen identifiziert (Anhang IIB). Tramec getriebe werden mit erklärung des herstellers geliefert. Die offizielle sprache der anweisungen für montage, betrieb und wartung ist englisch. Die anwendung von standard-getriebe in atex klassifizierten bereichen ist absolut verboten. Alle nachstehenden Warnhinweise beziehen sich auf den Einsatz von Getrieben und Getriebemotoren, deren Bewegung, Installation, Anlass, Instandhaltung und Reparatur von Fachpersonal durchgeführt werden sollen (gemäß IEC 364), das Kenntnis über die im vorliegenden Handbuch enthaltenen Informationen hat.

Falls vorhanden, werden spezielle Komponenten mit zusätzlichen Informationen ausgestattet (falls nicht vorhanden, bitte anfordern). Darüber hinaus wird eingehend darauf hingewiesen, sich an folgendes zu halten:

- an die eventuell auf den Aufklebern der Getriebe und/oder Motoren angegebenen Sicherheitssymbole;
- an die Anleitungen, die sich auf die Anlage beziehen;
- an die im Hinblick auf die korrekte Installation applizierten Richtlinien;
- an die geltenden gesetzlichen Sicherheitsvorschriften

Alle im vorliegenden Handbuch angegebenen Getriebe und Getriebemotoren sind für industriellen Einsatz in einer Umgebungstemperatur von -20°C bis +40°C und in einer max. Höhe von 1000 m über dem Meeresspiegel vorgesehen.

Für die Installation von Elektromotoren, Verstellgetrieben, Frequenzumrichtern, usw. muss man sich an die Anweisungen in den entsprechenden Unterlagen (falls nicht vorhanden, bitte anfordern) halten.

Die technischen Daten und die Informationen zu den Einsatzbedingungen der Getriebe und Getriebemotoren werden auf den Typenschildern und in den jeweiligen technischen Katalogen wiedergegeben.

Sollten anderweitige Einsätze vorgesehen sein, muss der Verantwortliche für die Installation zusätzliche Schutzmaßnahmen treffen und sie entsprechend garantieren.

Der Einsatz der Getriebe und Getriebemotoren in ihrer Standardausführung ist unter folgenden Bedingungen nicht gestattet:

- in salzhaltiger Umgebung
- in aggressiver Atmosphäre mit Explosionsgefahr
- in einer besonders feuchten Umgebung
- bei Vorhandensein von Flüssigkeiten oder im Tauchbetrieb



È richiesta l'autorizzazione scritta per l'utilizzo dei riduttori e motoriduttori nelle applicazioni riguardanti il sollevamento di ascensori o altri dispositivi utilizzati per lo spostamento di persone.

I riduttori e motoriduttori possono presentare situazioni di pericolo per l'operatore dovute a:

- parti in movimento durante il funzionamento
- superfici con temperature superiori a 50°C
- parti sotto tensione (nei motori elettrici)

Qualora sia necessario effettuare interventi sui riduttori e motoriduttori di messa a punto, manutenzione, riparazione, è indispensabile accertare che:

- la macchina sia ferma
- il motore ed eventuali dispositivi ausiliari siano scollegati dall'alimentazione di rete
- siano attivati i dispositivi di sicurezza che impediscono avviamenti involontari
- eventuali dispositivi meccanici di blocco del carico siano attivi (ovviamente dovranno essere disinseriti prima della messa in funzione della macchina)

#### **Attenzione!**

**Possono verificarsi danni gravi a persone o a impianti a causa di:**

- Utilizzo improprio
- installazione non corretta
- rimozione delle protezioni
- imperfetta connessione ad organi di collegamento
- mancanza di verifiche periodiche
- assenza di manutenzione

Arrestare la macchina e procedere alle opportune verifiche se si dovessero riscontrare le seguenti anomalie:

- aumento eccessivo della temperatura
- rumorosità eccessiva
- vibrazioni

*Prior written authorization is needed if the reducers or the gear motors are to be installed in lifts or other apparatuses for the transportation of people.*

*Reducers and gear motors may be a danger to the operator due to:*

- *moving parts whilst the machine is in operation*
- *surfaces with temperatures exceeding 50°C*
- *live electrical parts (in electric motors)*

*If reducers or gear motors need to be either adjusted or serviced, please ensure that:*

- *the machine is stopped*
- *motor and auxiliary devices are disconnected from the mains*
- *safety devices preventing undesired starts are enabled*
- *mechanical devices for blocking the load are enabled. They will obviously have to be disabled before restarting the machine.*

#### **Caution!**

**People may be seriously injured or damage may occur to equipment in case of:**

- *Improper use*
- *Incorrect installation*
- *Removal of safety devices*
- *couplers not properly connected*
- *Failure to carry out regular checks*
- *Failure to carry out servicing*

*Stop the machine and perform necessary checks in case of:*

- *excessively high temperature*
- *excessive noise coming from the machine*
- *vibrations*

Für den Einsatz der Getriebe und Getriebemotoren in Fahrstuhle oder anderen Einrichtungen für den Personentransport ist eine schriftliche Genehmigung erforderlich.

Getriebe und Getriebemotoren können aufgrund folgender Vorfaelle Gefahr für den Bediener darstellen:

- sich während des Betriebs bewegenden Teile
- Flächen mit Temperaturen über 50°C
- unter Spannung stehende Teile (bei Elektromotoren)

Im Falle von Einstellung, Instandhaltung oder Reparatur an den Getrieben und Getriebemotoren muss es unbedingt überprüft werden, dass:

- die Maschine sich im Stillstand befindet;
- der Motor und eventuelle Hilfsvorrichtungen vom Stromnetz getrennt sind;
- Sicherheitsvorrichtungen, die einen plötzlichen bzw. unerwünschten Anlauf verhindern, aktiviert sind;
- mechanische Lastenblockierungsvorrichtungen aktiviert sind (diese müssen natürlich vor der Inbetriebsetzung der Maschine ausgeschaltet werden).

#### **Achtung!**

**Schwere Personen-oder Anlageschäden können durch folgendes verursacht werden:**

- unangemessener Einsatz
- fehlerhafte Installation
- Abnahme der Schutzvorrichtungen
- fehlerhafte Verbindung an die Anschlussorgane
- mangelnde Ausführung der regelmäßigen Kontrollen
- keinerlei Instandhaltung

Die Maschine muss beim Vorliegen folgender Anomalien angehalten und entsprechend überprüft werden:

- übermäßiger Temperaturanstieg
- erhöhter Geräuschpegel
- Vibrationen



## 2.0 STATO DI FORNITURA

### Ricevimento

Al ricevimento dei riduttori e motoriduttori, verificarne l'integrità e, dove questa risulti compromessa, evitare l'installazione e contestare immediatamente al vettore il difetto riscontrato.

### Imballo

Esso differisce dalla quantità e dalle dimensioni dei prodotti, per cui (salvo specifiche concordate) verranno utilizzati imballi su pallet con pellicola di polietilene nastrati e reggiati, carton pallet o semplicemente cartoni.

Dove necessario, i riduttori verranno separati con adeguati materiali (schiuma, carta, cartone, ecc.).

Lo smaltimento dei materiali da imballo deve essere effettuato nel rispetto della legislazione vigente in materia.

### Verniciatura e protezioni

Serie Series Serie	Grandezza Size Baugröße	Verniciatura interna Inner painting Innenlackierung	Verniciatura esterna (BLU RAL 5010) Outer painting (BLUE RAL 5010) Außenlackierung (BLAU RAL 5010)		Piani lavorati Machined surfaces Bearbeitete Flächen	Alberi / Shafts / Wellen
			Tipo e caratteristiche vernice Paint type and features Lacktyp und -eigenschaften	Verniciabile Can be painted Lackierbar		
<b>X - K - H</b>	30 - 75	Nessuna None keine	Nessuna (carcasce in Alluminio) None (aluminum case) keine (Gehäuse aus Aluminium)	Sì - con prodotti sintetici monocomponente e bicomponente Yes, with one-component and bi-component synthetic products Ja - mit synthetischen Einfach-oder Bikomponente	Alluminio / Aluminum / Aluminium	Alberi cavi e sporgenti protetti con olio antiruggine Hollow and projecting shafts coated with antirust oil Mit Rostschutzöl geschützte Hohlwellen und vorstehende Wellen
<b>T</b>	56 - 63					
<b>Z</b>	71 - 225	come esterno as outer paint wie Außenlackierung	Preverniciato con polveri epossidiche (resistente agli agenti atmosferici e aggressivi) Pre-painted with epoxy powders (resistant to weather conditions and aggressive agents) Vorlackiert mit Epoxypulvern (widerstandsfähige gegen Umwelteinflüsse und aggressive Mittel)	Sì - dopo sgrassatura e carteggiatura Yes, after degreasing and sanding Ja - nach Entfettung und Schleifen	Protetti con olio antiruggine Coated with antirust oil Mit Rostschutzöl geschützt	
<b>P</b>	63 - 160					
<b>M</b>						
<b>R</b>	19 - 48					
<b>X - K - H</b>	90 - 110					

### Caratteristiche vernice

Il gruppo viene fornito già verniciato con polvere bugnata tipo BLU RAL 5010 (escluse naturalmente le parti lavorate per appoggi di fissaggio e/o accoppiamenti). Si tratta di polveri termoindurenti a base di resine poliesteri, modificate con resine epossidiche, particolarmente indicate all'impiego in virtù della loro stabilità termica e delle loro capacità anticorrosive.

## 2.0 CONDITIONS OF SUPPLY

### Goods receipt

On receipt of reducers and gear motors always check for transport damage. Never install a damaged unit and report the detected defect to the forwarding agent.

### Packing

Packing may differ depending on product quantity and size. Unless otherwise agreed, goods will be packed either on pallet wrapped with polyethylene film, taped and strapped or packed on case pallet or simply in cartons.

If necessary reducers shall be separated using proper material such as foam, paper, cardboard and so forth.

Packing materials should be disposed of in compliance with current laws.

### Paint and protections

### Paint specifications

The unit is painted with rusticated powder type BLUE RAL 5010 (excluding machined parts intended to be matched with fastening and/or coupling parts). This type of powder is thermosetting, has a basis of polyester resins and is modified with epoxy resins; it is therefore particularly suitable for this kind of utilization thanks to its thermal stability and anticorrosive features.

## 2.0 LIEFERBEDINGUNGEN

### Empfang der Waren

Bei dem Empfang der Getriebe und Getriebemotoren muss es geprüft werden, dass sie unversehrt sind. Sollte dies nicht der Fall sein, dürfen sie nicht installiert werden. Der festgestellte Defekt soll sofort dem Frachtführer angezeigt werden.

### Verpackung

Die Verpackung fällt je nach Menge und Maß der Produkte unterschiedlich aus, daher werden die Getriebe (falls nicht anderweitig abgestimmt) auf Paletten mit Polyäthylen-Folie und Klebeband oder Umreifung, auf Kartonpaletten oder einfach nur in Kartons verpackt.

Falls erforderlich werden die Getriebe durch das Einfügen von angemessenem Material (Schaumstoff, Papier, Karton, u.ä.) voneinander getrennt. Die Entsorgung des Verpackungsmaterials muss der betreffenden gesetzlichen Vorschriften gemäß erfolgen.

### Lackierung und Schutz

### Lackeigenschaften

Die Einheit wird bereits mit Rustikapulver vom Typ BLAU RAL 5010 lackiert (ausgenommen davon sind natürlich die bearbeiteten Teile, die als Auflagefläche für Befestigungen und/oder Kupplungen dienen). Hierbei handelt es sich um duroplastische Pulverlacke auf der Grundlage von Polyesterharzen, die durch Zugabe von Epoxidharzen geändert wurden, und die sich wiederum aufgrund ihrer Eigenschaften wie Wärmefestigkeit und Korrosionsschutz für diesen Einsatz besonders eignen.



Risultato di prove effettuate su lamierini UNICHIM

Spessore del film	60/80 micron
Gloss	60 ± 7

Durezza (matita) H:

Resistenza al calore ISO 7724	24 ore a 165°C (bianco)
Ritenzione della brillantezza	BUONA

Resistenza alla corrosione:

Nebbia salina ASTM B 117 a 35°C da 100 a 150 ore in funzione del trattamento preliminare di sabbiatura o pallinatura con successiva asportazione di polvere, senza presenza di ruggine o istering	
Prova KESTERNIK	12 cicli senza ruggine di penetrazione

Invecchiamento accelerato:

ASTM G 53 Inalterato

Note: Nel caso di ambienti particolarmente aggressivi, o per altre esigenze, provvedere ad ulteriori verniciature speciali usando vernice anticorrosiva e proteggendo il bordo esterno degli anelli di tenuta al fine di evitare che si essicchi la gomma con conseguenti screpolature e perdite d'olio.

La verniciatura non deve assolutamente interessare le parti in gomma ed i fori esistenti sui tappi di sfiato, quando presenti.

Per applicazioni all'aperto è opportuno proteggere il gruppo mediante l'applicazione di grasso idrorepellente, specialmente in corrispondenza delle sedi rotanti degli anelli di tenuta, della zona albero cavo - perno macchina e sulle parti lavorate non utilizzate per il fissaggio.

Result achieved after testing UNICHIM metal sheets

Film thickness	60/80 micron
Gloss	60 ± 7

Hardness (pencil) H:

heat resistance in compliance with ISO 7724	24 hours at 165°C (white)
Gloss resolution level	GOOD

Corrosion strength:

Salt fog test ASTM B117 at 35°C from 100 to 150 hours depending on preliminary sandblasting or shot-peening and later dust removal, with no sign of rust or blistering.	
KESTERNIK test	12 cycles with no sign of penetration rust

Quick aging:

ASTM G 53 unchanged

Note: Use special corrosion-proof paints in case of particularly aggressive environment or for any other special needs. Protect the outer edge of oil seals so that seal rubber does not dry up and crack, thus causing oil leaks.

Rubber parts and breather plug holes, if present, should not be painted.

For outdoor applications apply water-repellent grease on the unit, especially on the rotary seats of the seal rings, in the area hollow shaft-machine pin, and on machine parts which are not used for fastening.

Ergebnisse der auf UNICHIM-Feinblechen durchgeführten Tests

Schichtstärke	60/80 Mikron
Gloss	60 ± 7

Härte (Bleistift) H:

Wärmefestigkeit ISO 7724	24 Stunden bei 165 °C (weiß)
Glanz-Vorethaltung	GUT

Korrosionsfestigkeit:

Salznebel Test ASTM B117 bei 35°C von 100 bis 150 Betriebsstunden abhängig von der Sand- oder Kugelstrahlvorbehandlung mit nachfolgendem Abtrag der Pulver, ohne Rost oder Blistering	
KESTERNIK test	12 Zyklen ohne Eindringungsrost

Vorzeitige Alterung:

ASTM G 53 unverändert

Hinweise: Beim Einsatz in einer besonders aggressiv wirkenden Umgebung oder unter anderen Anforderungen sind weitere Speziallackierungen mit Rostschutzfarbe notwendig. Der Aussenrand der Ölabdichtringe soll entsprechend geschützt werden, damit der Gummi nicht austrocknet und damit Risse und Ölverluste verhindert werden können.

Die ggf. vorhandenen Gummiteile und die an den Entlüftungsstopfen vorhandenen Bohrungen dürfen absolut nicht lackiert werden.

Für Applikationen im Freien sollte die Einheit durch Auftragen von wasserabstossendem Fett geschützt werden (insbesondere an den Drehsitzen der Dichtringe, im Bereich der Hohlwelle-Maschinestift und der bearbeiteten, nicht für die Befestigung verwendeten Teile).

## Identificazione

Tutti i riduttori e motoriduttori sono identificati da una targa contenente i dati relativi alle caratteristiche costruttive e funzionali (definendo in tal modo sia i precedenti accordi contrattuali che le caratteristiche funzionali).

Evitarne la rimozione o il danneggiamento in quanto i dati contenuti dovranno essere citati nell'eventuale richiesta di ricambi e per il riconoscimento di eventuali interventi in garanzia.

## Identification

*All reducers and gear motors have an identification plate which contains data concerning manufacturing and operation (thus defining both the foregoing contractual agreements and the features of operation).*

*Never remove or damage this identification plate as mentioned data should always be specified when ordering spare parts and when submitting warranty claims.*

## Identifikation

Alle Getriebe und Getriebemotoren werden durch ein Typenschild gekennzeichnet, auf dem die Bau- und Betriebseigenschaften angegeben werden (dadurch werden sowohl die vorausgehenden vertraglich festgelegten Baueigenschaften als auch die Betriebseigenschaften festgelegt).

Das Typenschild darf nicht abgenommen oder beschädigt werden, weil die darauf angegebenen Daten im Fall einer Ersatzteilanforderung und im Hinblick auf eine eventuelle Anerkennung der Garantie angegebenen werden sollen.

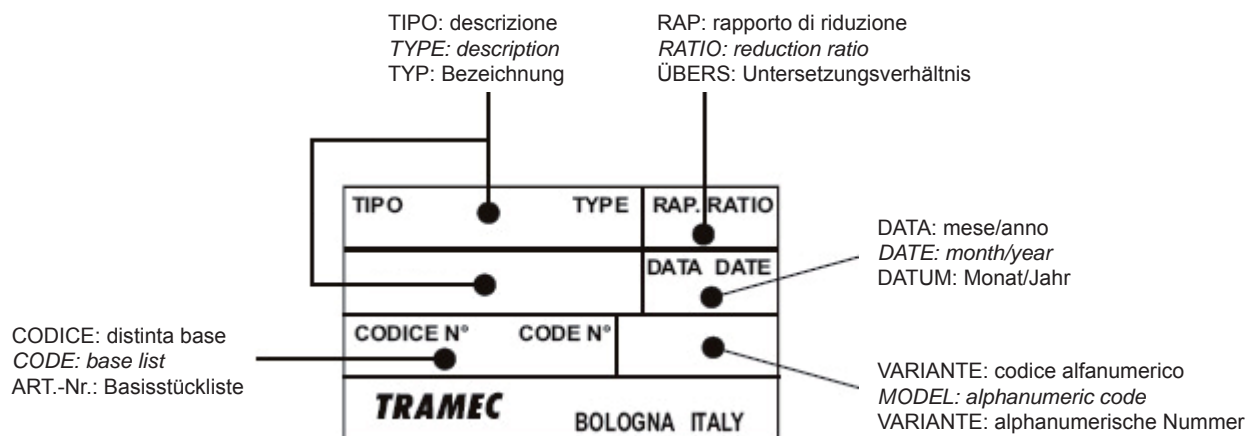

## Movimentazione e stoccaggio

Nel sollevamento è opportuno utilizzare apposite attrezzature (ganci, cinghie, catene, golfari, ecc.) adeguatamente dimensionati al peso da sollevare e nel rispetto delle comuni norme di sicurezza verificando inoltre che il carico sia bilanciato.

I punti di aggancio situati sui riduttori (identificabili nei fori presenti sulla carcassa, utilizzati per il fissaggio) servono per il sollevamento del solo riduttore.

Evitare l'utilizzo del foro filettato in testa agli alberi sporgenti e il golfare del motore.

## Handling and storage

*Lift the unit using suitable lifting devices (such as hooks, belts, chains, eyebolts, etc.) in full compliance with current safety standards. Also ensure that the load is properly balanced.*

*Reducer lifting points (identifiable with the holes on the casing, which are used for fastening) must be used to lift the reducer only.*

*Do not use the threaded hole at the end of the projecting shafts and the motor eyebolt.*

## Bewegung und Einlagerung

Für das Heben der Einheit sollten angemessene Vorrichtungen (Häken, Riemen, Ketten, Transportösen, usw.) verwendet werden, die für das zu hebende Gewicht bemessen sind und die der Sicherheitsvorschriften entsprechen. Ebenso muss es überprüft werden, ob die Gewichtsverteilung der Last ausgeglichen ist.

Die Ankoppelungspunkte sind mit den Bohrungen auf dem Gehäuse identifizierbar, denen zur Befestigung dienen. Die Ankoppelungspunkte dienen zu dem Heben des Getriebes als einzelne Einheit.

Die Benutzung der am Kopf der vorstehenden Welle liegenden Gewindebohrung und der Tragöse des Motors ist jedoch zu vermeiden.



Il corretto stoccaggio dei prodotti ricevuti richiede l'esecuzione delle seguenti attività:

- Escludere aree all'aperto, zone esposte alle intemperie o con eccessiva umidità.
- Interporre sempre tra il pavimento ed i prodotti, pianali in legno o di altra natura per impedire il diretto contatto col suolo.
- Evitare l'accatastamento dei riduttori.

I riduttori forniti completi di olio lubrificante devono essere immagazzinati nella stessa posizione di montaggio in cui verranno installati.

Proteggere le superfici lavorate non verniciate, gli alberi e le tenute con olio antiruggine o grasso controllandone periodicamente lo stato di conservazione. Ad intervalli di 4-5 mesi effettuare una rotazione dell'albero lento.

Il normale periodo di stoccaggio, previsto a temperature comprese fra -20°C e +40°C in ambiente coperto asciutto, pulito, secco e in assenza di vibrazioni, è di 1 anno a condizione che siano state assicurate adeguate protezioni durante il trasporto.

Tale periodo può essere protratto fino a 2 anni adottando i seguenti accorgimenti:

Proteggere le superfici lavorate non verniciate, gli alberi e le tenute con olio antiruggine o grasso controllandone periodicamente lo stato di conservazione.

Riempire totalmente con olio i riduttori forniti senza, avendo cura di ripristinare il livello corretto in fase di installazione.

Ad intervalli di 4-5 mesi effettuare una rotazione dell'albero lento.

Per periodi di stoccaggio superiori a 2 anni o in ambienti diversi da quelli sopra citati consultare il Servizio tecnico Tramec.

### 3.0 INSTALLAZIONE

Attenersi alle seguenti indicazioni.  
Togliere eventuali protezioni presenti nell'imballo.

Orientare il riduttore nella corretta posizione di montaggio richiesta in fase di ordine verificando tramite l'apposita spia (dove previsto) il livello del lubrificante immesso.

*To properly store reducers and gear motors, proceed as follows:*

- *do not store outdoors, in areas subject to weather conditions or in highly humid environments.*
- *never store the goods directly onto the floor but place them onto wooden pallets or any other suitable surface in order to avoid direct contact with the ground*
- *reducers should never be stacked.*

*Reducers which are filled with oil should be stored in the same mounting position they are going to be installed in.*

*Apply antirust oil or grease onto unpainted machine surfaces, shafts and seals. Check that they are in good condition at regular intervals. Rotate the output shaft every 4-5 months.*

*Provided that reducers and gear motors are stored indoors in a dry, clean and vibration-free place at a temperature ranging between -20° and +40°C, and provided that they had been duly protected during transport, they can be stored for one year.*

*Proceed as follow to extend storage time to two years:*

*Apply antirust oil or grease onto unpainted machine surfaces, shafts and seals and check that they are in good condition at regular intervals.*

*Fully fill with oil the reducers which were delivered empty. Before installing the reducer, the oil must be returned to the operating level.*

*Rotate the output shaft every 4-5 months.*

*Please contact Tramec Technical Service Department for storage over two years or storage in environments other than the specified ones.*

### 3.0 INSTALLATION

*Please follow the instructions below.  
Remove all protections in the packing.*

*Position the reducer in the correct mounting position which was specified in the order and check the oil level through the oil window (if available).*

Die korrekte Einlagerung der Produkte erfordert folgende Maßnahmen:

- Keine Einlagerung im Freien oder in Plätze, die von Witterungseinflüssen oder starker Feuchtigkeit betroffen sind
- Zwischen Boden und Produkten immer Flachböden aus Holz oder anderem Material einfügen, so dass ein direkter Kontakt mit dem Boden vermieden wird.
- Vermeiden, dass die Getriebe übereinander gestapelt werden.

Die bereits mit Schmieröl gelieferten Getriebe müssen in der gleichen Position gelagert werden, in der sie später montiert werden sollen.

Die bearbeiteten jedoch nicht lackierten Flächen, die Wellen und die Dichtungen sollen mit Rostschutzöl oder Fett geschützt werden. Regelmäßig soll deren Zustand kontrolliert werden. Die Abtriebswelle muss in Zeitabständen von 4-5 Monaten gedreht werden.

Die normale Lagerungszeit sieht Temperaturen zwischen -20°C und +40°C in einem überdachten, sauberen, trockenen und vibrationsfreiem Platz vor und beläuft sich auf die Dauer 1 Jahres, wenn während des Transports die angemessenen Schutzvorrichtungen gesichert wurden.

Die Lagerungszeit kann dank Ergreifung folgender Maßnahmen bis auf 2 Jahre hinausgezogen werden.

Die bearbeiteten, jedoch nicht lackierten Flächen, die Wellen und die Dichtungen müssen mit Rostschutzöl oder -fett geschützt werden. Den entsprechenden Erhaltungszustand regelmäßig kontrollieren.

Die ohne Öl gelieferten Getriebe vollständig mit Öl füllen. Bevor die Maschine in Betrieb genommen wird, ist der richtige Ölstand wiederherzustellen.

In Zeitabständen von 4-5 Monaten muss die Abtriebswelle gedreht werden.

Für Einlagerung über 2 Jahre oder in Plätze, die nicht mit den o.g. übereinstimmen, muss ein Techniker der Tramec konsultiert werden.

### 3.0 INSTALLATION

Die folgenden Anleitungen sind zu befolgen.  
Die eventuell in der Verpackung vorhandenen Schutzvorrichtungen abnehmen.

Das Getriebe in die auftragsgemäß korrekte Einbaulage bringen, dabei durch die Ölstandskontrolle (wo vorgesehen) den Ölstand überprüfen.



**Il montaggio di riduttori in posizioni diverse da quelle specificate in fase di ordine può portare ad un rapido danneggiamento degli organi interni.**

Nei riduttori forniti completi di olio e provvisti di tappi olio sostituire il tappo chiuso superiore con quello di sfianto fornito in dotazione.

Per i motoriduttori che si trovano in prossimità di carterature, verificare che sia garantito dal lato ventola del motore un flusso d'aria sufficiente per il corretto raffreddamento del gruppo.

I riduttori e i motoriduttori devono essere protetti dalle intemperie e dall'irraggiamento diretto del sole garantendo però adeguati spazi per l'aerazione e per l'ispezione.

Verificare che il senso di rotazione sia quello richiesto in fase di ordine.

Pulire accuratamente le superfici di fissaggio (asportando, se necessario, eventuali tracce di vernice) e verificarne la perfetta planarità e rigidità.

Assicurarsi che il fissaggio sia stabile al fine di evitare l'insorgere di vibrazioni che potrebbero causare rumorosità, allentamento delle viti e il verificarsi di possibili rotture a fatica.

Nelle viti di fissaggio riduttore-macchina e riduttore flangia, si consiglia l'utilizzo di adesivi bloccanti di media resistenza per evitare la possibilità di allentamenti e consentire comunque successivi smontaggi.

Se nell'applicazione sono previsti sovraccarichi di lunga durata, occorre prevedere dispositivi di limitazione della coppia, frizioni, ecc.

È opportuno garantire il corretto allineamento fra il riduttore e il motore e/o eventuali organi di collegamento; dove possibile, è preferibile utilizzare giunti elastici.

Se il motore è montato direttamente sulla flangia del riduttore, assicurarsi che non venga generato un effetto leva e che le due flange risultino complanari.

In applicazioni dove eventuali perdite di lubrificante possono causare inquinamento del prodotto o altri danni, effettuare delle frequenti ispezioni, ed eventualmente prevedere carterature supplementari o utilizzare lubrificanti per industria alimentare.

***If reducers are installed in a position other than the mounting position specified in the order, this may cause damage to its inner parts.***

*Replace the upper plug with the supplied breather plug in reducers which are delivered filled with oil and equipped with oil plugs.*

*Ensure that gear motors, which are close to housings, have enough space on the motor fan side to enable them to cool down.*

*Reducers and gear motors should be protected against bad weather or direct sun light and should also have enough space around them in order to allow proper ventilation and inspection.*

*Ensure that direction of rotation is as ordered.*

*Carefully clean all fastening surfaces, remove all paint residues and check for perfect flatness and stiffness.*

*Ensure that the reducer is firmly fastened in order to prevent vibrations which might cause noise, screw loosening and possible fatigue failure.*

*Apply medium-strength adhesives onto the screws fastening the reducer to the machine and the flange to prevent any slackening yet to allow subsequent necessary disassembly.*

*If the application requires long-lasting overloads, torque limiters, clutches and so forth should be installed.*

*Reducer, motor and/or all connecting parts should be duly aligned. If possible, it is advisable to use flexible joints.*

*If the motor is directly installed onto the reducer flange, ensure that no lever force is applied and that both flanges are in the same plane.*

*Perform frequent checks in case of applications in which oil leaks may contaminate the product or cause other damage. If necessary fit additional housings or use lubricants for the food industry.*

**Die Montage der Getriebe in einer Einbaulage, der von der in der Bestellung angegebenen Position abweicht, kann zu einer schnellen Beschädigung der inneren Bestandteile führen.**

Im Fall der bereits mit Öl gefüllten und mit Ölschraube ausgestatteten Getriebe muss die obere, geschlossene Verschluss-schraube durch den mitgelieferten Entlüftungsschraube ersetzt werden.

Bei Getriebemotoren, die nahe an Verkleidungsteilen angeordnet sind, muss es überprüft werden, dass auf der Seite des Motorlüfterrads ein ausreichender Luftfluss für die korrekte Kühlung der Einheit gewährleistet ist.

Die Getriebe sowie die Getriebemotoren müssen vor Witterungseinflüssen und direkter Sonneneinstrahlung geschützt werden, dabei muss für die Belüftung und die Inspektion ein angemessener Freiraum gewährleistet werden.

Überprüfen, dass die Drehrichtung der in der Bestellung angeforderten Richtung entspricht.

Die Befestigungsflächen sorgfältig reinigen (dabei ggf. Lackreste entfernen) und die perfekte Ebenheit und Festigkeit überprüfen.

Sich darüber vergewissern, dass die Befestigung stabil ist, um das Entstehen von Schwingungen zu verhindern, die zu hohen Geräuschpegeln, zu dem Lockern der Schrauben und zu möglichen Ermüdungsbrüchen führen könnten.

An den Befestigungsschrauben von Getriebe-Maschine und Getriebe-Flansch wird es empfohlen, einen mittelstarken Klebstoff zu verwenden. Damit wird das Eintreten von Lockerungen verhindert, jedoch wird ein späterer Ausbau noch ermöglicht.

Falls die Applikation Überlasten von langer Dauer vorsieht, müssen entsprechende Vorrichtungen zur Begrenzung des Drehmoments, Kupplungen, usw. verwendet werden.

Eine korrekte Fluchtung zwischen Getriebe und Motor und/oder eventuellen Verbindungsteilen soll gewährleistet werden. Womöglich dürfen elastische Verbindungskupplungen verwendet werden.

Wird der Motor direkt am Getriebeflansch montiert, muss man sich darüber vergewissern, dass dadurch kein Hebeleffekt erzeugt wird und dass die beiden Flanschen komplanar sind.

Falls eventuelle Schmiermittelverluste die Verschmutzung des Produkts oder andere Schäden verursachen könnten, müssen häufig Inspektionen vorgenommen werden; ggf. dürfen zusätzliche Verkleidungsteile vorgesehen oder Schmiermittel für Einsatz in der Lebensmittelindustrie verwendet werden

In ambienti inquinanti adottare gli opportuni accorgimenti per evitare la contaminazione del lubrificante.

*In polluting environments take all necessary steps to avoid lubricant contamination.*

Se l'applicazione prevede frequenti avviamenti e arresti, è consigliabile richiedere il motore con sonde termiche incorporate.

*If the application requires frequent starts and stops, a motor with built-in thermal feeler is recommended.*

### Installazione riduttori con allbero lento cavo

### Installing reducers with hollow output shaft

Per tutti i riduttori con alberi cavi (con cava per linguetta), il montaggio corretto deve essere eseguito come indicato di seguito.

*All reducers featuring hollow shafts (i.e. key way), should be installed as described below.*

Per il montaggio e lo smontaggio dei riduttori con gola per anello elastico, procedere come raffigurato in fig.1\_01 e fig.1\_03.

*Install and remove reducers with spring ring groove as shown in figures 1\_01 and 1\_03.*

Per il fissaggio assiale di questi riduttori con cava linguetta si può adottare il sistema raffigurato in fig.1\_02.

*Axial fastening of the reducers with key way occurs as shown in fig. 1\_02.*

In mit Schadstoff belasteten Plätze müssen angemessene Maßnahmen getroffen werden, um die Verschmutzung des Schmiermittels zu vermeiden.

Sind bei der Applikation häufige Anlauf- und Stoppschaltungen vorgesehen, wird es empfohlen, den Motor mit eingebauten Thermofühler anzufordern.

### Installation der Getriebe mit Abtriebshohlwelle

Für alle Getriebe mit Hohlwelle (mit Keilnut) muss die korrekte Montage den nachstehenden Angaben gemäß erfolgen:

Für die Montage und den Ausbau von Getrieben mit Federlingnut die Angaben in Abb. 1\_01 und Abb. 1\_03 befolgen.

Für die axiale Befestigung der mit Keilnut versehenen Getriebe kann das in Abb. 1\_02 dargestellten Verfahren angewendet werden.

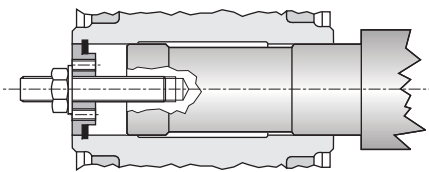

Montaggio Fig. 1\_01  
Installing Fig. 1\_01  
Montage Fig. 1\_01

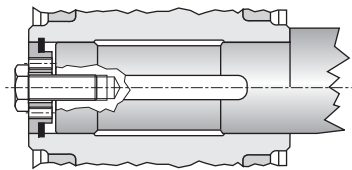

Fissaggio assiale Fig. 1\_02  
Axial fastening Fig. 1\_02  
Axiale Befestigung Fig. 1\_02

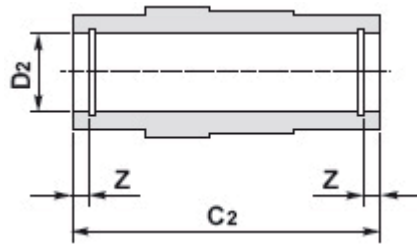

Albero lento cavo  
Hollow output shaft  
Abtriebs-Hohlwelle

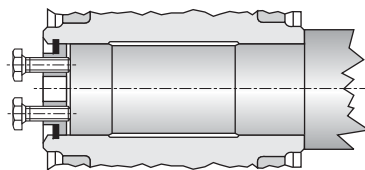

Smontaggio Fig. 1\_03  
Removing Fig. 1\_03  
Ausbau Fig. 1\_03

	T																					
	56		63			71B			90B - 80C		112B - 100C			140B 125C		180B 160C		200B 180C		225B 200C		
<b>C2</b>	100		120			115			130		155			180		220		260		300		
<b>D2 H7</b>	20	25	25	28	30	24	28	30	32	30	35	42	40	45	55	50	70	60	90	80	100	90
<b>Z</b>	—	—	—	—	—	—	—	—	8.7	8.4	11		11.9		15.4	15.9	18.9		20	—		

	Z															
	71A		90A 80B-80C			112A 100B-100C			140A 125B-125C		180A 160B-160C		180B 180C		225A 200B 200C	
<b>C2</b>	115		130			155			180		220		260		300	
<b>D2 H7</b>	24	28	32	30	35	42	40	45	55	50	70	60	90	80	100	90
<b>Z</b>	—	—	8.7		8.4	11			11.9		15.4	15.9	18.9		20	—

	P												
	63		80		100	125		160					
<b>C2</b>	101		130		155	180		220					
<b>D2 H7</b>	25	28	30	30	35	38	40	45	50	55	60	65	70
<b>Z</b>	7.3		8.5		10.8			12		15.5			

	M													
	63B		80B		100B		125B	140B		160B		180B		
<b>C2</b>	115		130		155		180	210		260		300		
<b>D2 H7</b>	35	38	40	45	50	55	60	65	70	75	80	85	90	100
<b>Z</b>	6.9		8.1		10.3		11.9	11.4	15.4	15.4	14.9	16.9		

	X - K - H															
	30		40		50		63		75		90		110		130	
<b>C2</b>	63		78		92		112		120		140		155		170	
<b>D2 H7</b>	14	18	19	25	24	25	28	30	35	42	45	48				

### Installazione riduttori con albero cavo e calettatore

Seguire la seguente procedura:

Rimuovere il calettatore dall'albero svitando le viti di bloccaggio gradualmente e in successione.

Pulire e sgrassare accuratamente le zone di accoppiamento fra l'albero lento del riduttore e l'albero della macchina.

Rimontare il calettatore sull'albero lento del riduttore e dopo aver effettuato l'accoppiamento dei due alberi (cavo riduttore e macchina) avvitare le viti gradualmente e in successione utilizzando una chiave dinamometrica tarata alle coppie di serraggio indicate nelle tabelle seguenti.

	T								
	56B 56C	63B 63C	71B	90B 80C	112B 100C	140B 125C	180B 160C	200B 180C	225B 200C
A	27	32	27	37	47	57	72	92	102
B	25	30	25	35	45	55	70	90	100
D	2	2	2	2	2	2	3	3	
DC	60	72	60	80	100	115	155	188	215
LC	22	24	22	26	31	31	39	50	54
L <sub>1</sub>	32	36	36	39	45	50	60	70	80
L <sub>2</sub>	61	75	68	82	100	115	143	175	200
L <sub>3</sub>	32	36	36	39	45	50	60	70	80
TS (Nm)	4	12	4	12	12	12	30	59	59

### Installazione riduttori con fissaggio pendolare

I riduttori con fissaggio pendolare vanno montati direttamente sull'albero della macchina e debbono essere vincolati tramite una staffa (braccio di reazione o tenditore) che ne contrasti la rotazione; il riduttore dovrà essere fissato sia radialmente che assialmente.

Il foro presente sul braccio di reazione deve avere un vincolo che sia libero assialmente e con un gioco sufficiente da permettere le piccole oscillazioni del riduttore durante il funzionamento.

Il mancato rispetto di queste condizioni può provocare carichi sui cuscinetti che ne possono pregiudicare l'integrità.

Eventuali pericoli derivanti dallo sfilamento del riduttore o sua rotazione, potranno essere evitati prevedendo apposite sicurezze.

### Installing reducers with hollow shaft and shrink disk

Proceed as follows:

Undo the fastening screws gradually one after the other and remove the shrink disk from the shaft.

Carefully clean and degrease the coupling surfaces between reducer output shaft and machine shaft.

Install the shrink disk onto the reducer output shaft and after having completed the coupling between the two shafts (reducer hollow shaft and machine shaft), tighten the screws gradually one after the other using a dynamometric wrench set to the tightening torque as specified in the following table.

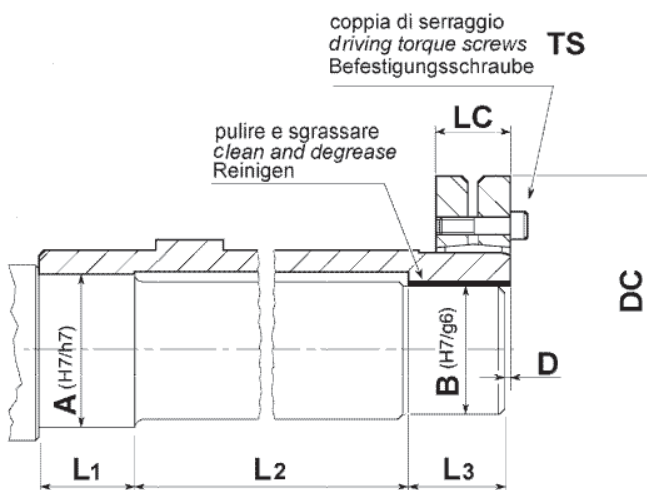

### Installing shaft-mounted reducers

Shaft-mounted reducers should be installed directly onto the machine shaft through a bracket (either a torque arm or a tensioner) which will counteract its rotation. The reducer should be fastened both radially and axially.

The hole on the torque arm should have a constraint which is axially free and also have enough play to allow the reducer to swing lightly whilst in operation.

Failure to follow the above instructions may lead to loads on the bearings and subsequent damage.

Suitable safety measures should be taken to avoid any risks resulting from reducer detachment or its rotation.

### Installation- Getriebe mit Hohlwelle und Schrumpfscheibe

Wie folgt verfahren:

Nach dem stückweisen und aufeinanderfolgenden Lösen der Feststellschrauben die Schrumpfscheibe von der Welle entfernen.

Die Kupplungsflächen zwischen der Abtriebswelle des Getriebes und der Maschinenwelle säubern und entfetten.

Die Schrumpfscheibe erneut auf die Getriebeabtriebswelle montieren, dann, nach der Kupplung der beiden Wellen (Hohlwelle des Getriebes und der Maschine) die Schrauben schrittweise und hintereinander mit einem Drehmoment-schlüssel anziehen, dem auf das in der nachstehenden Tabelle angegebene Anzugsmoment eingestellt ist.

	Z						
	71A	90A 80B 80C	112A 100B 100C	140A 125B 125C	180A 160B 160C	180B 180C	225A 200B 200C
A	27	37	47	57	72	92	102
B	25	35	45	55	70	90	100
D	2	2	2	2	2	3	3
DC	60	80	100	115	155	188	215
LC	22	26	31	31	39	50	54
L <sub>1</sub>	36	39	45	50	60	70	80
L <sub>2</sub>	68	82	100	115	143	175	200
L <sub>3</sub>	36	39	45	50	60	70	80
TS (Nm)	4	12	12	12	30	59	59

### Installation - Aufsteckgetriebe

Die Aufsteckgetriebe werden direkt an die Maschinenwelle montiert und müssen mit der Maschine über einen Bügel (Drehmomentstütze oder Spannvorrichtung) verbunden werden, welchen der Drehung der Getriebe entgegenwirkt. Das Getriebe muss sowohl radial als auch axial befestigt werden.

Die in der Drehmomentstütze vorhandene Bohrung muss eine Bindung aufweisen, die axial frei ist und die ein ausreichendes Spiel hat, sodass geringe Schwingungen der Getriebe während des Betriebs möglich sind.

Die mangelnde Einhaltung dieser Bedingungen kann zu Lasten auf die Lager und folglich auf deren Beschädigung führen.

Eventuell durch das Ablösen des Getriebes oder seine Umdrehung verursachten Gefahren können durch das Anbringen entsprechender Sicherheitsvorrichtungen vermieden werden.

## Installazione di organi di collegamento

La tolleranza consigliata per i fori degli organi da calettare è ISO H7, per carichi uniformi e leggeri.

Per carichi pesanti e presenza di urti, si consiglia una tolleranza ISO K7.

Il montaggio di componenti con interferenza dovrà essere effettuato riscaldando a 80 - 100 °C l'organo (con foro) da calettare.

Per gli alberi prevedere tolleranze ISO h6.

Per il montaggio utilizzare i fori filettati in testa agli alberi e dei tiranti; **evitare l'uso del martello** in quanto urti ripetuti possono danneggiare irrimediabilmente i cuscinetti.

Altre raccomandazioni da tenere in considerazione sono:

- Verificare che i tensionamenti delle catene e delle cinghie non siano eccessivi; considerare che il valore di tensione va sommato al carico generato da tali organi durante il funzionamento, pertanto il valore risultante deve sempre essere inferiore al valore consentito dal riduttore
- Se è necessario all'utilizzatore montare accessori a sbalzo quali alberi, pulegge ecc., in entrata e/o in uscita dal riduttore si consiglia di limitare quanto più è possibile il braccio di leva stando il più possibile vicino alla carcassa del riduttore stesso e di verificare che il tiro risultante sull'albero, in entrata e/o in uscita, durante il funzionamento sia sempre inferiore al valore del carico radiale ammesso dal riduttore.
- Le trasmissioni ad ingranaggi non devono avere zone di contatto senza gioco.

## 4.0 LUBRIFICAZIONE

La lubrificazione nei riduttori avviene per sbattimento. Nel caso in cui la potenza applicata sia superiore alla potenza termica ammessa, è necessario fare uso di scambiatori di calore che riducano la temperatura dell'olio entro limiti ammissibili.

L'utilizzo di lubrificanti adeguati alle condizioni operative, consente ai riduttori di raggiungere le condizioni ottimali; a tale proposito riportiamo la tabella degli oli consigliati per uso industriale.

## Installing connecting parts

*Recommended tolerance for the holes in parts to be shrunk on is ISO H7 for uniform and light loads.*

*In case of heavy loads and possible occurrence of shocks, an ISO K7 tolerance is recommended.*

*Mounting with interference should occur after having heated up to 80 – 100 °C the part (with hole) to be shrunk-on.*

*Recommended tolerances for shafts are ISO H6.*

*For the installation use the threaded holes on the shaft ends and on the connecting rods. **Do not hammer** as repeated shocks may irreversibly damage the bearings.*

*Please also consider the following:*

- *ensure that chains and belts are not overtightened. Please note that tension value should be added to the load produced by the parts during reducer operation. The final value should always be lower than the admissible reducer value.*
- *Should it be necessary for the user to mount overhanging accessories such as shafts, pulleys, etc., at either the gearbox input or output, we recommend to keep the lever arm as short as possible, to mount the accessory as close as possible to the gearbox housing and to check that the shaft tension, at input and/or output, during operation is always lower than the radial load allowed by the gearbox.*
- *gear drives should not have contact areas without play.*

## 4.0 LUBRICATION

*Reducers are splash lubricated. If the applied power is higher than the admissible thermal power, heat exchangers should be employed to lower the oil temperature within the allowed limits.*

*The use of lubricants which are suitable for current operating conditions will allow the reducer to achieve peak efficiency. The table below shows the recommended oils for industrial use.*

## Installation der Verbindungsteilen

ISO H7 ist die empfohlene Toleranz für die Bohrungen der zu verbindenden Teilen bei gleichmässigen und leichten Lasten. Bei schweren Lasten und beim Vorliegen von Stößen wird eine Toleranz gemäß ISO K7 empfohlen.

Vor der Montage von Komponenten mit Interferenz muss das zu verbindende Teil (Teil mit Bohrung) auf 80 - 100 °C erhitzt werden.

Für die Wellen sind Toleranzen gemäß ISO h6 vorzusehen.

Bei der Montage sind die Gewindebohrungen am Kopf **der Wellen und der Zugstangen zu verwenden**. Der Gebrauch eines Hammers bei der Montage ist zu vermeiden, weil wiederholte Hammerschläge zu irreparablen Schäden an den Lagern führen könnten.

Weitere zu berücksichtigende Empfehlungen:

- Überprüfen, dass die Ketten und die Riemen nicht übermäßig gespannt sind; hier muss berücksichtigt werden, dass der Spannungswert und der von Bestandteilen während des Betriebs erzeugten Last zusammen summiert werden müssen. Der sich daraus ergebende Wert muss also immer unter den vom Getriebe zulässigen Wert liegen.
- Sollte der Benutzer Zubehörteile mit Auskrugung montieren (z. B. Wellen, Scheiben, usw., entweder am Getriebeantrieb oder -abtrieb), ist es ratsam, den Hebelarm so kurz wie möglich zu machen und den geringsten Abstand zwischen Zubehörteil und Getriebegehäuse zu halten. Es ist auch sicherzustellen, dass die Wellenzugkraft am Antrieb und/oder am Abtrieb während des Betriebs immer niedriger als die zulässige Radialbelastung ist.
- Die Zahnradantriebe dürfen keine Kontaktfläche ohne Spiel aufweisen.

## 4.0 SCHMIERUNG

Was die Schmierung der Getriebe betrifft. Handelt es sich um eine Ölspritzschmierung Wenn die angewandte Leistung über der zulässigen Wärmeleistung liegt, müssen Wärmeaustauscher verwendet werden, die die Öltemperatur auf die zulässigen Grenzwerte bringen.

Das Verwenden von an die Betriebsbedingungen angepassten Schmiermitteln ermöglicht den Getrieben, optimale Leistung zu erzielen. Im Nachstehenden ist eine Tabelle, in der die für industriellen Einsatz empfohlenen Öle angegeben werden.



ISO VG		OLIO MINERALE / MINERAL OIL - MINERALÖL			OLIO SINTETICO / SYNTHETIC OIL / SYNTETISCHES ÖL						
		460	320	220	460	320	220	150			
Temperatura ambiente Amb.Temp. Tc (°C) Umgebungstemperatur		5° a 45°	0° a 40°	-5° a 35°	-15° a 100°	-20 a 90°	-25° a 80°	-30° a 70°			
FORNITORE / MANUFACTURER / HERSTELLER	MINERALE / MINERAL / MINERAL	MINERALE / MINERAL / MINERAL									
		SHELL		Omala OIL 460	Omala OIL 320	Omala OIL 220					
		BP		Energol GRXP 460	Energol GRXP 320	Energol GRXP 220					
		TEXACO		Meropa 460	Meropa 320	Meropa 220					
		CASTROL		Alpha SP 460	Alpha SP 320	Alpha SP 220					
		KLUBER		Lamora 460	Lamora 320	Lamora 220					
	MOBIL		Mobilgear 634	Mobilgear 632	Mobilgear 630						
	PAG	Tecnologia PAG (polialcoliglicoli) / PAG Tecnologia (polyalkyleneglycol) / PAG (Polyalkylglykole)									
		SHELL					Omala S4 WE 460	Omala S4 WE 320	Omala S4 WE 220	Omala S4 WE S 150	
		BP					Energol SGXP460	Energol SGXP320	Energol SGXP220	Energol SG 150	
		AGIP					Synlube CLP 460	Synlube CLP 320	Synlube CLP 220	Agip Blasias S 320	Agip Blasias S 220
	PAO	Tecnologia PAO (polialcoliolefini) / PAO Tecnologia (polialphaolefin) / PAO (Polyalphaolefine)									
		SHELL					Omala OIL RL/HD 460	Omala OIL RL/HD 320	Omala OIL RL/HD 220	Omala OIL RL/HD 150	
		CASTROL					Alpha Synt 460	Alpha Synt 320	Alpha Synt 220	Alpha Synt 150	
		MOBIL					SHC 634	SHC 632	SHC 630	SHC 629	

I riduttori TRAMEC, con lubrificazione a vita, sono forniti completi di olio sintetico del tipo:  
**SHELL OMALA S4 WE 320**

**Attenzione!**

È estremamente pericoloso e dannoso miscelare tra loro le tre categorie di oli.

Non miscelare mai tra loro gli oli sintetici appartenenti a diverse tecnologie (la tecnologia PAG non è compatibile con la PAO).

Nel caso si volesse cambiare tipologia di olio impiegato, avente cioè una tecnologia differente da quello impiegato, occorre eseguire prima un lavaggio interno del riduttore per pulirlo accuratamente.

*TRAMEC reducers packed for life are filled with synthetic oil:  
**SHELL OMALA S4 WE 320***

**Caution!**

*It is dangerous and damaging to mix oils belonging to the three different categories.*

*Never mix different synthetic oils together. PAG oils are not compatible with PAO oils.*

*Before filling the reducer with a different type of oil (i.e. a different technology), wash thoroughly the inside of the reducer.*

Die TRAMEC-Getriebe mit lebenslanger schmierung werden bereits mit syntetischen Öl geliefert. Öltyp:  
**SHELL OMALA S4 WE 320**

**Achtung!**

Es ist äußerst gefährlich und schädlich die drei Ölkategorien untereinander zu vermischen.

Niemals synthetische Öle miteinander vermischen, die unterschiedlichen Technologien angehören (die PAG-Technologie ist nicht mit der PAO-Technologie kompatibel).

Möchte man das Öl mit einem anderen Typ wechseln (d.h. mit einem Öl, dem einer anderen Technologie gehoert) muss der Innenbereich des Getriebes erst ausgewaschen bzw. gründlich gereinigt werden.

## Riduttori ad assi ortogonali

I riduttori ortogonali (ad esclusione dei tipi TF56 e TF63, con lubrificazione a vita) sono predisposti per lubrificazione ad olio e sono muniti di tappi di carico, livello e scarico d'olio.

Una pompa per la lubrificazione forzata dei cuscinetti superiori è fornita a richiesta sulle grandezze 125, 140, 160, 180, 200 e 225 nella posizione di montaggio VA.

Nella posizione B6 e B7 è previsto un tappo di sfiato con asta di livello.

Nel caso in cui sia presente il dispositivo antiritorno è necessario l'utilizzo di olio lubrificante sintetico PAG, classe di viscosità ISO 150.

### Posizione di montaggio e quantità di lubrificante (litri)

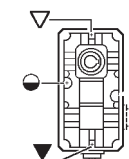
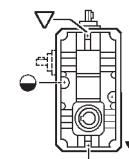
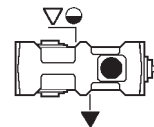
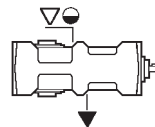
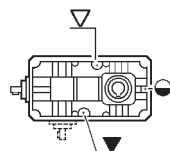
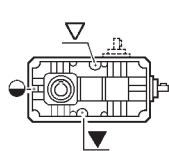

T	B3	B8	B6	B7	VA	VB
56B				0.30		
56C				0.35		
63B				0.35		
63C				0.40		
71B	0.6		0.7	0.5		0.8
80C	1.1		1.5	1.3		1.5
90B	1.0		1.4	1.2		1.3
110C	2.0		2.6	2.3		2.8
112B	1.8		2.6	2.3		2.4
125C	3.8		4.8	4.5		5.0
140B	3.6		4.6	4.3		4.3
160C	7.0		9.2	8.7		10.0
180B	7.5		9.7	9.2		8.0
180C	9.5		14.0	13.0		15.5
200B	12.5		15.0	14.0		17.5
200C	13.5		19.0	18.0		19.5
225B	14.5		19.0	18.0		18.7

## Bevel helical reducers

*Apart from TF56 and TF63 reducers which are life lubricated, bevel helical reducers must be filled with oil and therefore they all have filler plugs, breathers and drain plugs.*

*A pump for the forced lubrication of the upper bearings is supplied on request for sizes 125, 140, 160, 180, 200 and 225 in the VA mounting position.*

*In the B6 and B7 position the breather plug is fitted with oil dipstick.*

*The utilization of PAG synthetic oil, viscosity class ISO 150, is necessary for the gearboxes equipped with back stop device.*

### Mounting position and lubricant quantity (liters)

## Kegelstirnradgetriebe

Die Kegelstirnradgetriebe (die Typen TF56 und TF63 mit Schmierung auf Lebensdauer ausgenommen) sind für die Ölschmierung ausgerüstet und mit Einfüll-, Ölstand- und Ablassschrauben ausgestattet.

Eine Pumpe für die Zwangsschmierung der oberen Lager kann auf den Baugrößen 125, 140, 160, 180, 200 und 225 in der Baulage VA auf Wunsch geliefert werden.

Für die B6 und B7 Version ist eine Entlüftungsschraube mit Ölstandanzeigel vorgesehen.

Getriebe mit einer Rücklaufsperr müssen mit PAG synthetischem Oel (Viskosität ISO150) betrieben werden.

### Baulage und Schmiermittelmenge (Liter)

## Riduttori ad assi paralleli

I riduttori ad assi paralleli sono forniti predisposti per la lubrificazione ad olio e sono muniti di tappi di carico, livello e scarico d'olio.

Una pompa per la lubrificazione forzata dei cuscinetti superiori è fornita a richiesta sulle grandezze 125, 140, 160, 180, 200 e 225 nella posizione di montaggio VA.

Nelle posizioni V1 e V3 è previsto un tappo di sfiato con asta di livello.

Nel caso in cui sia presente il dispositivo antiritorno è necessario l'utilizzo di olio lubrificante sintetico PAG, classe di viscosità ISO 150.

## Parallel shaft reducers

*Parallel shaft reducers must be filled with oil and therefore they all have filler plugs, breathers and drain plugs.*

*A pump for the forced lubrication of the upper bearings is supplied on request for sizes 125, 140, 160, 180, 200 and 225 in the VA mounting position.*

*In the V1 and V3 positions the breather plug is fitted with oil dipstick.*

*The utilization of PAG synthetic oil, viscosity class ISO 150, is necessary for the gearboxes equipped with back stop device.*

## Parallelengetriebe

Die Parallelengetriebe werden für die Ölschmierung ausgerüstet und mit entsprechenden Einfüll-, Pegelkontroll- und Ablassschrauben ausgestattet.

Eine Pumpe für die Zwangsschmierung der oberen Lager kann auf den Baugrößen 125, 140, 160, 180, 200 und 225 in der Baulage VA auf Wunsch geliefert werden.

In den Baulagen V 1 und V3 ist jeweils eine Entlüftungsschraube mit Oelstandsanzeigel vorgesehen.

Getriebe mit einer Rücklaufsperr müssen mit PAG synthetischem Oel (Viskosität ISO150) betrieben werden.

### Posizione di montaggio e quantità di lubrificante (litri)

### Mounting position and lubricant quantity (liters)

### Einbaulage und Schmiermittelmenge (Liter)

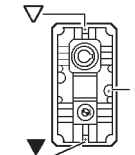
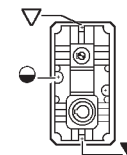
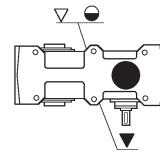
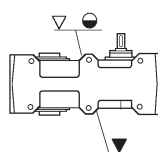
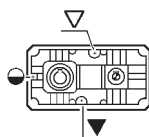

Z	B3	V1	V3	VA	VB
71A	0.6	0.75	0.75	0.6	0.7
80B - 80C	1.1	1.5	1.5	1.5	1.5
90A	1.2	1.5	1.5	1.2	1.3
100B - 100C	2.0	2.6	2.6	2.8	2.8
112A	2.0	2.6	2.6	2.0	2.2
125B - 125C	3.8	4.8	4.8	5.0	5.0
140A	3.7	4.8	4.8	3.7	4.0
160B - 160C	7.0	9.2	9.2	10	10.0
180A	7.1	9.2	9.2	7.1	7.8
180B - 180C	9.5	14.0	13.0	15.5	16.0
200B - 200C	13.5	19.0	19.0	19.5	19.5
225A	13.5	17.5	17.5	13.5	14.8

### Riduttori pendolari

I riduttori pendolari sono forniti predisposti per lubrificazione ad olio e sono muniti di tappi di carico, livello e scarico olio.

Nel caso in cui sia presente il dispositivo antiritorno è necessario l'utilizzo di olio lubrificante sintetico PAG, classe di viscosità ISO 150.

### Shaft-mounted reducers

*Shaft-mounted reducers must be filled with oil and therefore they all have filler, level and drain plugs.*

*The utilization of PAG synthetic oil, viscosity class ISO 150, is necessary for the gearboxes equipped with back stop device.*

### Aufsteckgetriebe

Aufsteckgetriebe werden fuer die Oelschmierung ausgerues-tet und werden mit entsprechenden Einfuell-, Oestand- und Ablassschrauben ausgestattet.

Getriebe mit einer Rücklaufsperrre müssen mit PAG syntheti-schem Oel (Viskosität ISO150) betrieben werden.

### Posizione di montaggio e quantità di lubrificante (litri)

### Mounting position and lubricant quantity (liters)

### Einbaulage und Schmiermittelmenge (Liter)

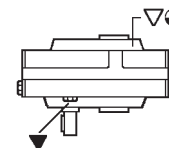
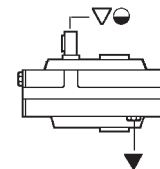
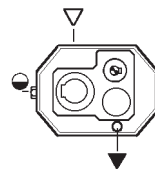
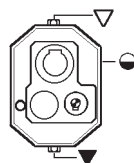
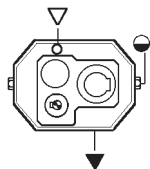
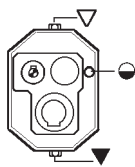

P	P1	P2	P3	P4	VA	VB
63A - 63B	0.55	0.45	0.55	0.45	0.7	0.7
80A - 80B	1.2	0.9	1.1	0.9	1.4	1.4
100A - 100B	2.2	1.8	2.2	1.8	2.8	2.8
125A - 125B	4.4	3.6	4.4	3.6	5.6	5.6
160A - 160B	8.8	7.2	8.8	7.2	11.2	11.2

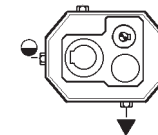
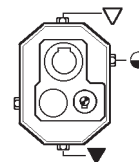
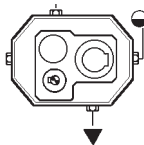
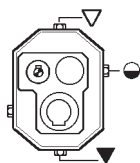

MA	P1	P2	P3	P4
63B	0.55	0.45	0.55	0.45
80B	1.2	0.9	1.1	0.9
100B	2.2	1.8	2.2	1.8
125B	4.4	3.6	4.4	3.6
140B	6.2	6.6	6.2	6.6
160B	8.8	7.2	8.8	7.2
180B	10.2	10.4	10.2	10.4

### Rinvii angolari

I rinvii angolari sono forniti predisposti per lubrificazione ad olio (ad esclusione della grandezza R19 lubrificata a vita) e sono muniti di tappi di carico, livello e scarico olio. Nella posizione B6 e B7 è previsto un tappo di sfiato con asta di livello.

#### Posizione di montaggio e quantità di lubrificante (litri)

### Right angle reducers

Right angle reducers (with the exception of size R19 which is packed for life) must be filled with oil and therefore they all have filler, level and drain plugs. In the B6 and B8 position the breather plug is fitted with oil dipstick.

#### Mounting position and lubricant quantity (liters)

### Winkelgetriebe

Winkelgetriebe (mit Ausnahme der R19 Größe, der lebenslang geschmiert ist) werden fuer di Oelschmierung ausgeruestest und werden mit entsprechenden Einfuell-, Oelstand- und Ablassschraube ausgestattet. Fur die B6 und B7 Version ist eine Entluftungsschraubeb mit Olstandanzeigel vorgesehen.

#### Einbaulage und Schmiermittelmenge (Liter)

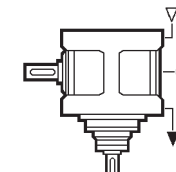
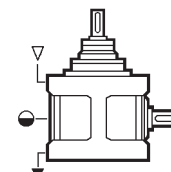
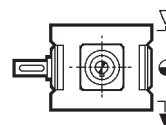
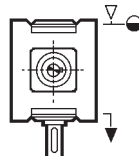
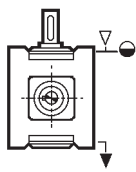
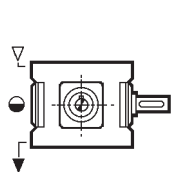

R	B3	B6	B7	B8	VA	VB
19	0.2	0.2	0.2	0.2	0.2	0.2
24	0.4	0.8	0.8	0.4	0.6	0.5
28	0.9	0.8	0.8	0.8	0.9	0.8
38	1.6	3.0	3.0	2.0	2.7	2.7
48	4.0	5.6	5.6	5.6	5.6	5.6

### Riduttori a vite senza fine

Riduttori a vite senza fine X, K e H sono forniti tutti e sempre completi di lubrificante sintetico (le grandezze 90 e 110 possono essere fornite prive di lubrificante solo su richiesta). Si raccomanda di precisare sempre in fase di ordine, la posizione di lavoro desiderata.

#### Posizione di montaggio

### Worm reduction gears

Worm reduction gears X, K and H up to frame size 75 are supplied filled with synthetic oil (size 90 and 110 only on request). Always specify designated mounting position on order.

#### Mounting position

### Schneckengetriebe

Schneckengetriebe X, K und H werden bis zur Baugröße 75 bereits mit synthetischem Schmiermittel gefüllt geliefert (Größe 90 und 110 nur auf Verlangen). Im Auftrag bitte immer die gewünschte Einbaulage angeben.

#### Einbaulage

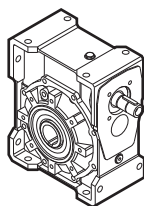

B3

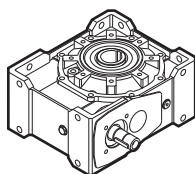

B6

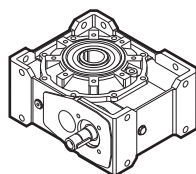

B7

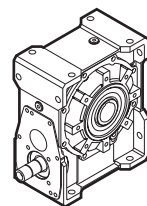

B8

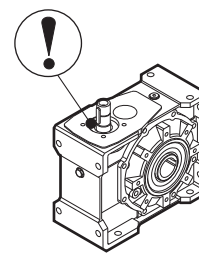

V5

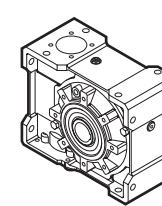

V6

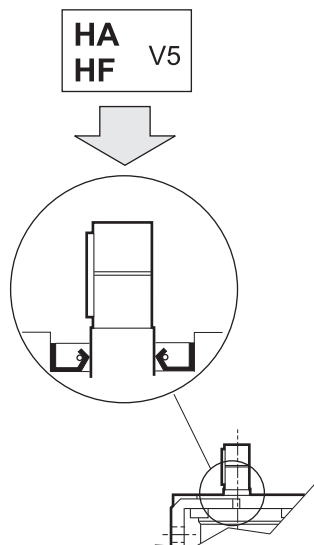

**Attenzione!** Nelle versioni HA e HF è indispensabile conoscere la posizione di lavoro in quanto nella configurazione V5 occorre posizionare in modo corretto il paraolio della vite, per preservare la corretta lubrificazione della coppia d'ingranaggi cilindrici del primo stadio di riduzione.

**Warning!** It is especially important to specify mounting position when ordering versions HA and HF. This is because the V5 configuration requires that the worm shaft oil seal be positioned accordingly in order to ensure proper lubrication of the first reduction spur gear set.

**Achtung!** Bei den Versionen HA und HF ist die Information bezüglich der Einbau- bzw. die Arbeitslage unbedingt erforderlich, da in der Konfiguration V5 der Ölabdichting der Schnaecke korrekt angeordnet werden muss, um eine korrekte Schmierung des Zylinderradpaars der ersten Stufe aufrecht zu erhalten.

**Quantità di lubrificante (litri) / Lubricant quantity (liters) / Schmiermittelmenge (Liter)**

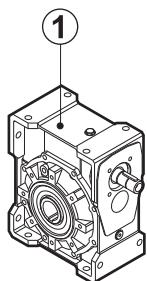

1	X - H	B3	B6 - B7	B8	V5 - V6
	30	0.015			
40	0.040				
50	0.080				
63	0.160				
75	0.260				
90	1.1	0.9	1	1.5	
110	2.2	1.8	1.6	2.6	
130	3.6	3	2.5	3.8	

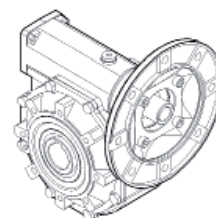

K	B3	B6 - B7	B8	V5 - V6
	30	0.015		
40	0.040			
50	0.080			
63	0.160			
75	0.260			
90	1	0.8	0.8	1.3
110	2	1.5	2	2
130	3	2.6	2.1	2.8

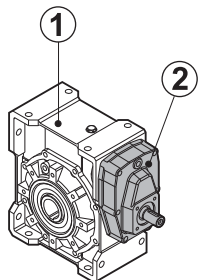

2	H	B3	B6 - B7	B8	V5 - V6
	40	0.040			
50	0.070				
63	0.140				
75	0.200				
90	0.200				
110	0.400				
130	0.400				

## 5.0 MESSA IN SERVIZIO

Prima della messa in servizio verificare che:

- Il riduttore sia montato correttamente e che il livello del lubrificante sia corretto
- il collegamento del motore elettrico sia corretto
- il senso di rotazione determinato dal motore installato sia quello voluto
- nei riduttori forniti con dispositivo antiritorno il senso di rotazione libero coincida con quello richiesto dalla macchina operatrice (**eventuali avviamenti nel senso bloccato possono danneggiare irrimediabilmente il riduttore e/o il motore**).

Con motori asincroni trifase, quando l'avviamento è a vuoto (o comunque a carico molto ridotto) è necessario avere:

- avviamenti dolci
- correnti di spunto basse
- sollecitazioni contenute
- avviamento stella-triangolo (normalmente per potenze > 15 kW, solo eccezionalmente si scende fino a 3 - 4 kW)

Si consiglia un rodaggio di 200-400 ore con carico ridotto per raggiungere un rendimento ottimale (livelli di temperatura più elevati sono da considerarsi normali in questa fase); al termine del rodaggio si consiglia una verifica del serraggio delle viti di fissaggio.

### Rischi Residui.

Per rischio residuo si intende un potenziale pericolo, impossibile da eliminare o parzialmente eliminato, che può provocare danni all'operatore se interviene con metodi e pratiche di lavoro non corrette.

### Pericolo in caso di perdita di olio.

- Non toccate a mani nude la zona della perdita, non eseguire nessuno tipo di manutenzione senza aver prima consultato il manuale di istruzioni.

### In caso di contatto con l'olio:

- non ingeritelo.
- non toccatevi da nessuna parte, in particolare gli occhi.
- lavatevi la zona di contatto con acqua corrente.

Attenzione: controllate periodicamente che non ci siano perdite di olio sotto la macchina, in modo da evitare di scivolare, si ricorda di usare sempre scarpe antinfortunistiche nelle vicinanze della macchina.

### - Pericolo di calore sulle carcasse dei riduttori.

Non toccate a mani nude la carcassa del riduttore, in caso di manutenzione aspettare che si raffreddi. Si raccomanda di usare guanti di protezione.

## 5.0 STARTING-UP

Check the following before starting-up the reducer:

- *the reducer is correctly installed and filled with the correct amount of lubricant*
- *the electric motor is correctly connected*
- *the direction of rotation brought about by the installed motor is as required*
- *the free rotation direction of reducers featuring back stop device coincides with that required by the machine (starts in the locked direction may cause irreversible damage to the reducer and/or the motor).*

*If three-phase asynchronous motors are subject to a loadless or reduced load start, they should:*

- *be gently started*
- *have low starting current*
- *be subject to limited stress*
- *feature star-delta starting (normally for power values > 15 kW, down to 3-4 kW only in exceptional cases).*

*A running-in time of 200-400 hours featuring a reduced load is recommended to achieve peak efficiency. Higher temperatures are normal at this stage. Please check for possible loosening of the fastening screws after running in the reducer.*

### Residual risks

*Residual risks are those potential dangers which is not possible to eliminate totally and which could cause damages to the operator should he intervene in the wrong way.*

### Risks in case of oil leakage

*Do not touch the leakage area with bare hands, any maintenance job should only be carried out after careful reading of the instruction manual.*

### In case of contact with oil:

- *do not swallow it*
  - *do not touch your body, specially the eyes*
  - *wash with running water the part which has come in contact with oil*
- Important: check at regular intervals that there are no leakages under the machine in order to prevent people from slipping. People should always wear safety shoes when near a machine.*

### -risks in case of hot gearbox housings

*do not touch the gearbox housing with bare hands. Before carrying out any maintenance job, wait until it cools down. Always wear work gloves.*

## 5.0 INBETRIEBNAHME

Vor der Inbetriebnahme muss folgendes überprüft werden:

- korrekte Montage des Getriebes und korrekter Ölstand
- korrekter Anschluss des Elektromotors
- korrekte, vom Motor bestimmten Drehrichtung
- bei Getrieben mit Rücklauf Sperre soll die freie Drehrichtung mit der von Arbeitsmaschine bestimmten Drehrichtung übereinstimmen (**eventuell in der blockierten Richtung erfolgenden Anläufe können zu irreparablen Schäden am Getriebe und/oder Motor führen**).

Bei dem Leeranlauf von dreiphasig Asynchronmotoren (oder beim Anlauf mit geringer Last) ist folgendes notwendig: sanfter Anlauf

- niedriger Anzugsstrom
- beschränkte Belastungen
- Stern-Dreieck Schaltung (normalerweise für Leistungen > 15 kW verwendet, nur ausnahmsweise geht der Wert auf 3 - 4 kW).

Eine Einlaufzeit von 200-400 Stunden mit einer reduzierten Last wird empfohlen, um dann die optimale Leistung zu erzielen (in dieser Phase sind höhere Temperaturen normal). Nach Ablauf der Einlaufzeit wird eine Anzugskontrolle an den Befestigungsschrauben empfohlen.

### Restgefahr

Restgefahr ist eine Gefahr, die ein unvermeidbares nicht offensichtliches Risiko bedeutet.

### Gefahr bei Ölverlust

Die Fläche mit nackten Händen nicht berühren. Wartungsarbeiten nur nach Nachsehen in dem Wartungsanleitung führen.

### Bei unbeabsichtigten Kontakt:

- kein Öl schlucken
- sich selbst und Augen insbesondere nicht berühren
- die in Berührung gekommenen Haut mit reichlich fließendem Wasser auswaschen.

Wichtig: regelmäßig soll geprüft werden, dass es unter der Maschine keine Ölverluste gibt, die Abrutschen verursachen könnten. Arbeiter sollen immer Sicherheitsschuhe tragen wenn in der Nähe der Maschine.

### -Gefahr bei heißen Getriebegehäusen

Das Getriebegehäuse nicht mit nackten Händen berühren. Wartungsarbeiten führen, nur nachdem das Gehäuse abgekühlt ist. Sicherheitshandschuhe sind immer zu tragen.



## 6.0 MANUTENZIONE

Durante il funzionamento verificare periodicamente la presenza di eventuali vibrazioni, temperatura, rumorosità ed effettuare un controllo visivo delle tenute.

### Attenzione!

Prima di effettuare gli interventi di manutenzione accertarsi che la macchina sia ferma, l'alimentazione disinserita e verificare che la temperatura dell'olio sia scesa a livelli di sicurezza per non causare ustioni agli operatori.

A macchina ferma verificare:

- il livello del lubrificante
- il livello di deterioramento del lubrificante ed eventualmente sostituirlo
- che i passaggi d'aria non siano ostruiti
- le superfici esterne del riduttore siano pulite al fine di garantire un corretto smaltimento del calore prodotto
- il corretto serraggio delle viti di fissaggio

Il cambio dell'olio può essere effettuato ad intervalli programmati come indicato dalla seguente tabella.

## 6.0 MAINTENANCE

*Check for possible vibrations, non-allowed temperatures, high noise level and visually check seals for leaks at regular intervals.*

### Caution!

*Before starting any maintenance job ensure that the machine is stopped, powered off and that the oil temperature is at safety level to avoid any risk for the operators of getting burned.*

*Check the following when the machine is stopped:*

- *oil is at correct level*
- *oil is not deteriorated. Change the oil if necessary*
- *passages for air are not clogged*
- *reducer outer surfaces are clean in order to ensure proper heat dissipation*
- *fastening screws are properly tightened*

*Oil change can be scheduled as specified in the table below.*

Base olio / <b>Oil base</b> / Ölgrundlage	Temperatura olio / <b>Oil temperature</b> / Öltemperatur		
	< 65 °C	65 - 80 °C	> 80 °C
Minerale / <i>Mineral oil</i> / Mineralöl	8000 h	4000 h	2000 h
Sintetico / <i>Synthetic oil</i> / Synthetisches Oel	25000 h	15000 h	12500 h

Prima di procedere alla sostituzione provvedere ad un accurato lavaggio interno del riduttore.

Nel caso di smontaggio di coperchi nei quali la funzione di tenuta è affidata al mastice, prima del rimontaggio è necessario pulire le superfici e ripristinare la tenuta.

*Before changing the oil it is necessary to thoroughly wash the inside of the reducer.*

*If covers featuring sealing putty need to be removed, clean the sealing surfaces and apply the putty before reinstalling the covers.*

## 6.0 INSTANDHALTUNG

Während des Betriebs müssen regelmäßig eventuelle Schwingungen, die Temperatur und den Geräuschpegel überprüft werden, ebenso ist eine Kontrolle an den Dichtungen erforderlich.

### Achtung!

Vor Beginn der Instandhaltungsarbeiten muss man sich darüber vergewissern, dass die Maschine sich im Stillstand befindet und die Stromversorgung abgeschaltet ist. Darüberhinaus muss es kontrolliert werden, dass die Öltemperatur unter das Sicherheitsniveau abgesunken ist, um zu vermeiden, dass sich die Bediener damit verbrennen können.

Bei stehender Maschine folgendes kontrollieren:

- den Schmiermittelpegel
- das Verderben des Schmiermittels, ggf. auswechseln
- dass die Luftpassagen nicht verstopft sind
- dass die Außenflächen des Getriebes sauber sind, so dass ein korrekter Wärmeabbau garantiert werden kann
- den korrekten Anzug der Befestigungsschrauben

Der Ölwechsel kann nach den in der nachstehenden Tabelle angegebenen Zeitabständen vorgenommen werden.

**TA/TF 56B - TA/TF 63B**

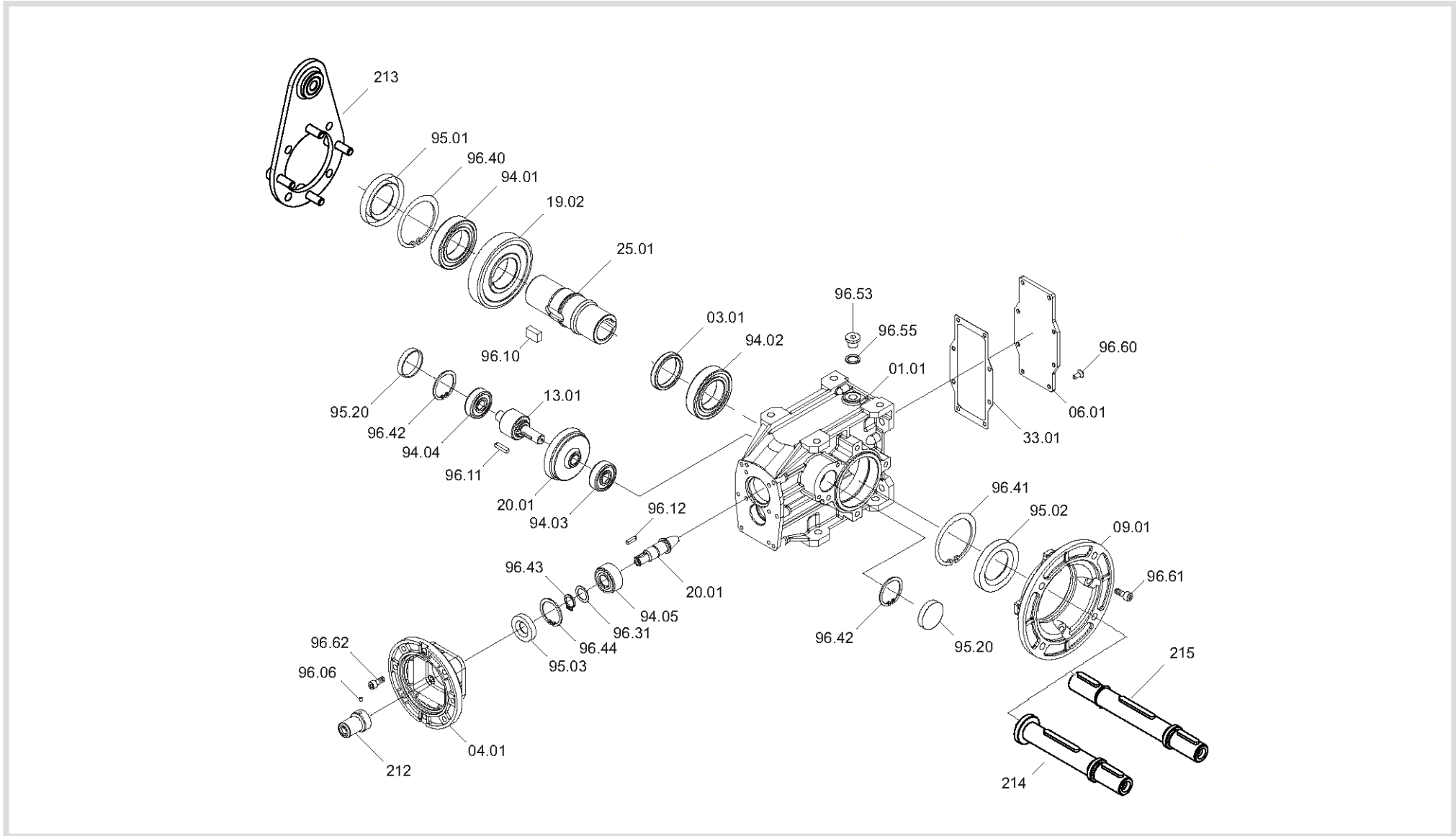



T	Cuscinetti / Bearings / Lager					Anelli di tenuta / Oilseals / Öldichtungen		
	TA - TF					TA - TF		
	94.01	94.02	94.03	94.04	94.05	95.01	95.02	95.03
<b>56B</b>	<b>6007</b> 35/62/14	<b>6007</b> 35/62/14	<b>6201</b> 12/32/10	<b>6201</b> 12/32/10	<b>3201</b> 12/32/15.9	<b>35/62/7</b>	<b>35/62/7</b>	<b>12/32/7</b>
<b>63B</b>	<b>6008</b> 40/68/15	<b>6008</b> 40/68/15	<b>6301</b> 12/37/12	<b>6301</b> 12/37/12	<b>3202</b> 15/35/15.9	<b>40/68/10</b>	<b>40/68/10</b>	<b>15/35/7</b>

Codice	Descrizione	Description	Beschreibung
01.01	Corpo	<i>Housing</i>	Gehäuse
03.01	Distanziale	<i>Spacer</i>	Distanzscheibe
04.01	Campana	<i>Bell</i>	Glocke
06.01	Coperchio chiuso	<i>Closed cover</i>	Geschlossener deckel
09.01	Flangia uscita	<i>Output flange</i>	Abtriebsflansch
13.01	Pignone cilindrico	<i>Cylindrical pinion</i>	Zyl.ritzel
19.02	Corona cilindrica uscita	<i>Cyl.output wheel</i>	Zyl.abtriebsrad
20.01	Coppia conica	<i>Bevel gear</i>	Kegelrad
212	Giunto	<i>Coupling</i>	Kupplung
213	Kit braccio di reazione	<i>Torque arm kit</i>	Drehmomentstütze
214	Kit albero lento sporgente	<i>Single output shaft kit</i>	Abtriebswelle
215	Kit albero lento bisporgente	<i>Double extended output shaft kit</i>	Doppelvorstehende abtriebswelle
25.01	Albero uscita cavo	<i>Hollow output shaft</i>	Abtriebshohlwelle
33.01	Guarnizione	<i>Gasket</i>	Dichtung
95.20	Cappellotto	<i>Closed oilseal</i>	Geschlossene oeldichtung

Codice	Descrizione	Description	Beschreibung
96.06	Grano	<i>Dowel</i>	Stift
96.10	Linguetta	<i>Key</i>	Keil
96.11	Linguetta	<i>Key</i>	Keil
96.12	Linguetta	<i>Key</i>	Keil
96.31	Rasamento	<i>Shim adjustment</i>	Ausgleichscheibe
96.40	Seeger	<i>Circlip</i>	Seeger
96.41	Seeger	<i>Circlip</i>	Seeger
96.42	Seeger	<i>Circlip</i>	Seeger
96.43	Seeger	<i>Circlip</i>	Seeger
96.44	Seeger	<i>Circlip</i>	Seeger
96.53	Tappo	<i>Plug</i>	Schraube
96.55	Rondella	<i>Washer</i>	Federring
96.60	Vite fissaggio	<i>Tightening screw</i>	Befestigungsschraube
96.61	Vite fissaggio	<i>Tightening screw</i>	Befestigungsschraube
96.62	Vite fissaggio	<i>Tightening screw</i>	Befestigungsschraube

**TA/TF 56C - TA/TF 63C**

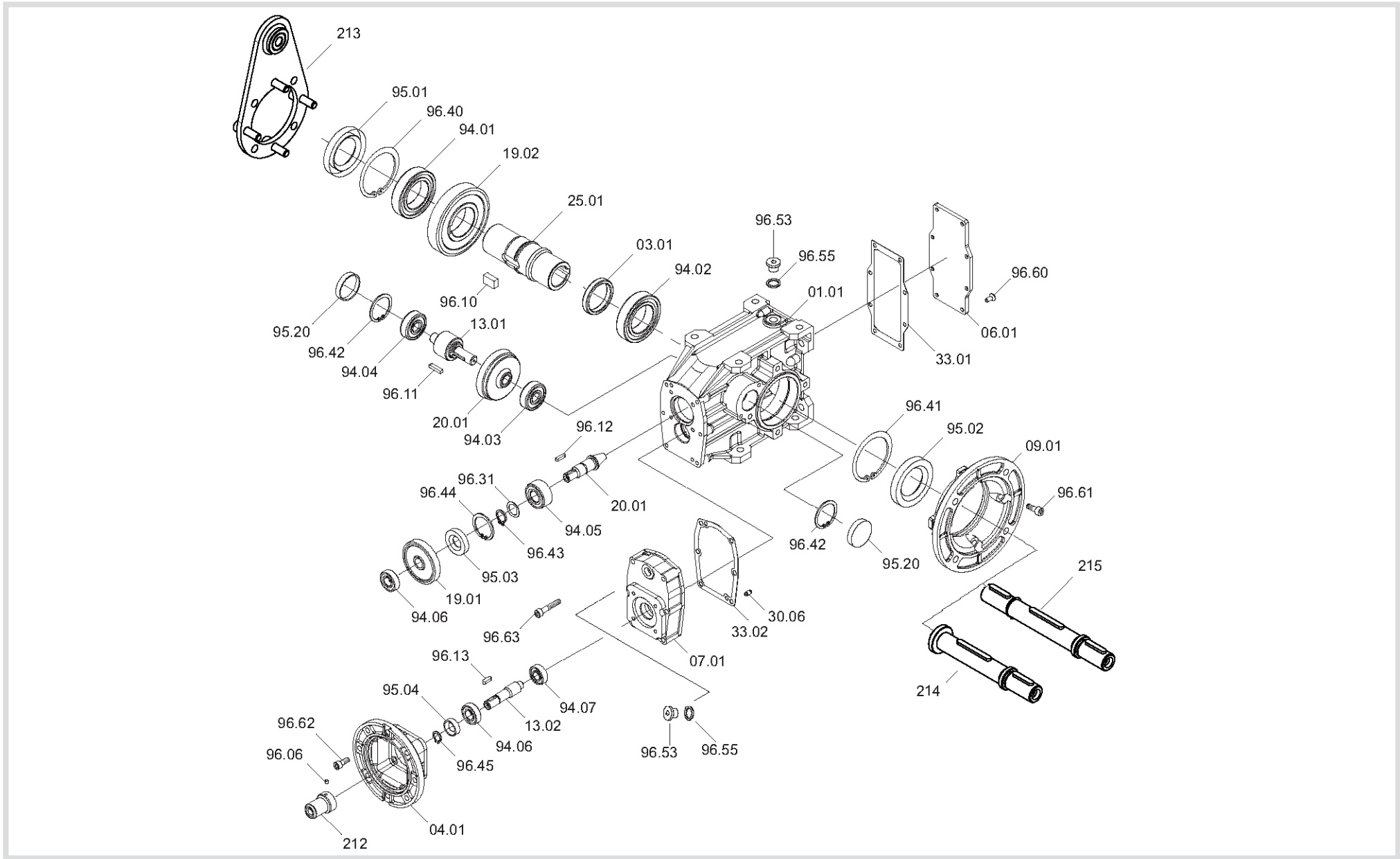



T	Cuscinetti / Bearings / Lager							Anelli di tenuta / Oilseals / Öldichtungen			
	TA - TF							TA - TF			
	94.01	94.02	94.03	94.04	94.05	94.06	94.07	95.01	95.02	95.03	95.04
<b>56C</b>	<b>6007</b> 35/62/14	<b>6007</b> 35/62/14	<b>6201</b> 12/32/10	<b>6201</b> 12/32/10	<b>3201</b> 12/32/15.9	<b>6001</b> 12/28/8	<b>6000</b> 10/26/8	35/62/7	35/62/7	12/32/7	12/22/7
<b>63C</b>	<b>6008</b> 40/68/15	<b>6008</b> 40/68/15	<b>6301</b> 12/37/12	<b>6301</b> 12/37/12	<b>3202</b> 15/35/15.9	<b>6001</b> 12/28/8	<b>6000</b> 10/26/8	40/68/10	40/68/10	15/35/7	12/22/7

Codice	Descrizione	Description	Beschreibung
01.01	Corpo	<i>Housing</i>	Gehaeuse
03.01	Distanziale	<i>Spacer</i>	Distanzscheibe
04.01	Campana	<i>Bell</i>	Glocke
06.01	Coperchio chiuso	<i>Closed cover</i>	Geschlossener deckel
07.01	Corpo precoppia	<i>First stage housing</i>	1stufig gehaeuse
09.01	Flangia uscita	<i>Output flange</i>	Abtriebsflansch
13.01	Pignone cilindrico	<i>Cylindrical pinion</i>	Zyl.ritzel
13.02	Pignone cilindrico	<i>Cylindrical pinion</i>	Zyl.ritzel
19.01	Corona cilindrica intermedia	<i>Intermed cylindrical wheel</i>	Mittel Zyl.rad
19.02	Corona cilindrica uscita	<i>Cyl.output wheel</i>	Zyl.abtriebsrad
20.01	Coppia conica	<i>Bevel gear</i>	Kegelrad
212	Giunto	<i>Coupling</i>	Kupplung
213	Kit braccio di reazione	<i>Torque arm kit</i>	Drehmomentstütze
214	Kit albero lento sporgente	<i>Single output shaft kit</i>	Abtriebswelle
215	Kit albero lento bisporgente	<i>Double extended output shaft kit</i>	Doppelvorstehende abtriebswelle
25.01	Albero uscita cavo	<i>Hollow output shaft</i>	Abtriebshohlwelle
30.06	Boccola centraggio	<i>Flanged bush</i>	Zentrierungsbuchse
33.01	Guarnizione	<i>Gasket</i>	Dichtung
33.02	Guarnizione precoppia	<i>First stage gasket</i>	1 stufig dichtung

Codice	Descrizione	Description	Beschreibung
95.20	Cappellotto	<i>Closed oilseal</i>	Geschlossene oeldichtung
96.06	Grano	<i>Dowel</i>	Stift
96.10	Linguetta	<i>Key</i>	Keil
96.11	Linguetta	<i>Key</i>	Keil
96.12	Linguetta	<i>Key</i>	Keil
96.13	Linguetta	<i>Key</i>	Keil
96.31	Rasamento	<i>Shim adjustment</i>	Ausgleichscheibe
96.40	Seeger	<i>Circlip</i>	Seeger
96.41	Seeger	<i>Circlip</i>	Seeger
96.42	Seeger	<i>Circlip</i>	Seeger
96.43	Seeger	<i>Circlip</i>	Seeger
96.44	Seeger	<i>Circlip</i>	Seeger
96.45	Seeger	<i>Circlip</i>	Seeger
96.53	Tappo	<i>Plug</i>	Schraube
96.55	Rondella	<i>Washer</i>	Federring
96.60	Vite fissaggio	<i>Tightening screw</i>	Befestigungsschraube
96.61	Vite fissaggio	<i>Tightening screw</i>	Befestigungsschraube
96.62	Vite fissaggio	<i>Tightening screw</i>	Befestigungsschraube
96.63	Vite fissaggio	<i>Tightening screw</i>	Befestigungsschraube

**TA..B - TC..B - TF..B**

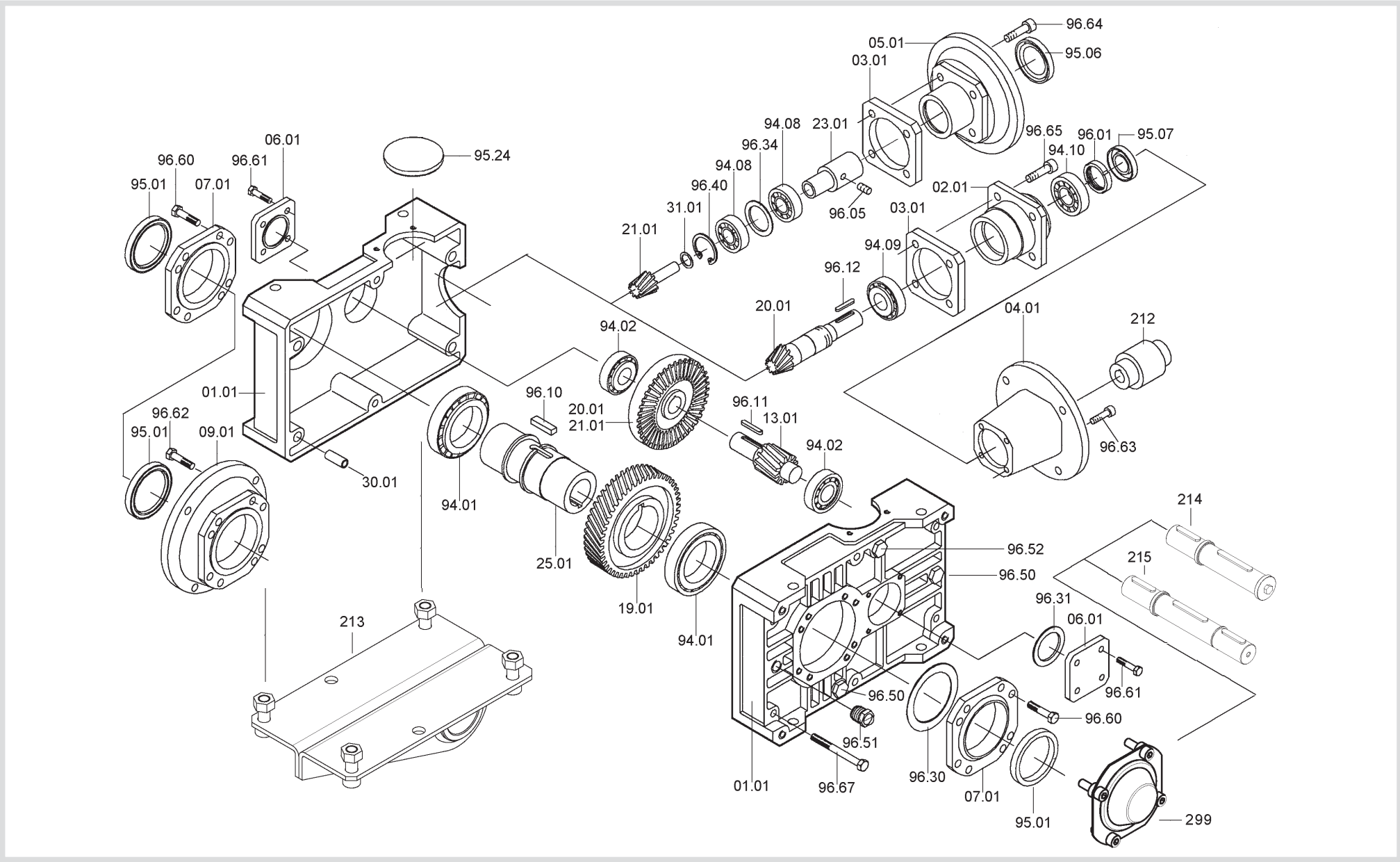



T	Cuscinetti / Bearings / Lager					Anelli di tenuta / Oilseals / Öldichtungen			
	TA - TC - TF		TC	TA - TF		TA - TC - TF	TC		TA - TF
	94.01	94.02	94.08	94.09	94.10	95.01	IEC	95.06	95.07
71B	32008 40/68/19	30302 15/42/14.25	7203 17/40/12	30203 17/40/13.25		40/56/8	63	25/52/7	15/40/10
							71	30/52/7	
							80	35/52/7	
							90	37/52/7	
90B	32010 50/80/20	30204 20/47/15.25	7205 25/52/15	32005 25/47/15		50/65/8	71 - 80	35/62/7	20/47/7
							90	40/62/8	
							100 - 112	45/62/8	
112B	32012 60/95/23	30305 25/62/18.25	7206 30/62/16	32006 30/55/17		60/80/10	80 - 90	40/72/10	25/58/10
							100 - 112	45/72/8	
							132	55/72/10	
140B	32015 75/115/25	32206B 30/62/21.25	7207 35/72/17	32007 35/62/18		75/95/10	80 - 90	45/80/10	30/62/7
							100 - 112	45/80/10	
							132	55/80/10	
							160	60/80/10	
180B	32019 95/145/32	31307 / (32208)* 35/80/22.75 / (40/80/24.75)*	7209 45/85/19	32009 45/75/20		95/125/12	100 - 112	55/100/10	40/80/10
							132 - 160	60/100/10	
							180	65/100/10	
							200	75/100/10	
200B	32024 120/180/38	31309 45/100/27.25	7209 45/85/19	33109 45/80/26		120/160/15	100 - 112	55/100/10	40/80/10
							132 - 160	60/100/10	
							180	65/100/10	
							200	75/100/10	
225B	32026 130/200/45	31310 50/110/29.25	—	33111 55/95/30	32011 55/90/23	130/160/12	—	—	50/90/10

Codice	Descrizione	Description	Beschreibung
01.01	Corpo	Housing	Gehäuse
02.01	Mozzo entrata	Ball-bearing hub	Antriebsnabe
03.01	Distanziale	Spacer	Distanzscheibe
04.01	Campana	Bell	Gloke
05.01	Flangia	Flange	Flansch
06.01	Coperchio chiuso	Closed cover	Geschlossener deckel
07.01	Coperchio aperto	Open cover	Geöffneter deckel
09.01	Flangia uscita	Output flange	Abtriebsflansch
13.01	Pignone cilindrico	Cylindrical pinion	Zyl.ritzel
19.01	Corona cilindrica uscita	Cyl.output wheel	Zyl.abtriebsrad
20.01	Coppia conica ta	Bevel gear ta	Kegelrad ta
21.01	Coppia conica tc	Bevel gear tc	Kegelrad tc
212	Giunto	Coupling	Kupplung
213	Kit braccio di reazione	Torque arm kit	Drehmomentstütze
214	Kit albero lento sporgente	Single output shaft kit	Abtriebswelle
215	Kit albero lento bisporgente	Double extended output shaft kit	Doppelvorstehende abtriebswelle
23.01	Manicotto	Coupling sleeve	Verbindungswelle
25.01	Albero uscita cavo	Hollow output shaft	Abtriebshohlwelle
299	Kit protezione albero uscita cavo	Output shaft protection kit	Schutzvorrichtung für abtriebswelle
30.01	Boccola di centraggio	Flanged bush	Zentrierungsbuchse
31.01	Rondella	Washer	Federring

Codice	Descrizione	Description	Beschreibung
95.24	Cappello	Closed oilseals	Federring
96.01	Ghiera autobloccante	Self-locking ring nut	Selbstsperrende Nutmutter
96.05	Grano	Dowel	Stift
96.10	Linguetta	Key	Keil
96.11	Linguetta	Key	Keil
96.12	Linguetta	Key	Keil
96.30	Rasamento	Shim adjustment	Ausgleichscheibe
96.31	Rasamento	Shim adjustment	Ausgleichscheibe
96.34	Rasamento	Shim adjustment	Ausgleichscheibe
96.40	Seeger	Circlip	Seeger
96.50	Tappo	Plug	Schraube
96.51	Tappo livello olio	Level plug	Ölstandsschraube
96.52	Tappo di sfato	Breather plug	Entlüftungsschraube
96.60	Vite fissaggio	Tightening screw	Befestigungsschraube
96.61	Vite fissaggio	Tightening screw	Befestigungsschraube
96.62	Vite fissaggio	Tightening screw	Befestigungsschraube
96.63	Vite fissaggio	Tightening screw	Befestigungsschraube
96.64	Vite fissaggio	Tightening screw	Befestigungsschraube
96.65	Vite fissaggio	Tightening screw	Befestigungsschraube
96.67	Vite fissaggio	Tightening screw	Befestigungsschraube





T	Cuscinetti / Bearings / Lager					Anelli di tenuta / Oilseals / Öldichtungen				
	TA - TC - TF			TC	TA - TF		TA - TC - TF	TC		TA - TF
	94.01	94.02	94.04	94.08	94.09	94.10	95.01	IEC	95.06	95.07
80C	32010 50/80/20	30204 20/47/15.25	30302 15/42/14.25	7203 17/40/12	30203 17/40/13.25	50/65/8	63	25/52/7	15/40/10	
							71	30/52/7		
							80	35/52/7		
							90	37/52/7		
100C	32012 60/95/23	30305 25/62/18.25	30204 20/47/15.25	7205 25/52/15	32005 25/47/15	60/80/10	71 - 80	35/62/7	20/47/7	
							90	40/62/8		
							100 - 112	45/62/8		
125C	32015 75/115/25	32206 30/62/21.25	30305 25/62/18.25	7206 30/62/16	32006 30/55/17	75/95/10	80 - 90	40/72/10	25/58/10	
							100 - 112	45/72/8		
							132	55/72/10		
160C	32019 95/145/32	32207 35/72/24.25	32206 30/62/21.25	7207 35/72/17	32007 35/62/18	95/125/12	80 - 90	45/80/10	30/62/7	
							100 - 112	45/80/10		
							132	55/80/10		
							160	60/80/10		
180C	32024 120/180/38	31309 45/100/27.25	32206 30/62/21.25	7207 35/72/17	32007 35/62/18	120/160/15	80 - 90	45/80/10	30/62/7	
							100 - 112	45/80/10		
							132	55/80/10		
							160	60/80/10		
200C	32026 130/200/45	31310 50/110/29.25	30307 35/80/22.75	7209 45/85/38	32009 45/75/20	130/160/12	100 - 112	55/100/10	40/80/10	
							132 - 160	60/100/10		
							180	65/100/10		
							200	75/100/10		

Codice	Descrizione	Description	Beschreibung
01.02	Corpo	Housing	Gehaeuse
02.01	Mozzo entrata	Ball-bearing hub	Antriebsnabe
04.01	Campana	Bell	Glocke
05.01	Flangia	Flange	Flansch
06.01	Coperchio chiuso	Closed cover	Geschlossener deckel
06.02	Coperchio chiuso	Closed cover	Geschlossener deckel
07.01	Coperchio aperto	Open cover	Geoffneter deckel
09.01	Flangia uscita	Output flange	Abtriebsflansch
13.01	Pignone cilindrico	Cylindrical pinion	Zyl.ritzel
13.02	Pignone cilindrico	Cylindrical pinion	Zyl.ritzel
18.01	Corona colindrica intermedia	Intermediate cyl. wheel	Mittel zyl.rad
19.01	Corona cilindrica uscita	Cyl.output wheel	Zyl.abtriebsrad
20.01	Coppia conica ta	Bevel gear ta	Kegelrad ta
21.01	Coppia conica tc	Bevel gear tc	Kegelrad tc
212	Giunto	Coupling	Kupplung
213	Kit braccio di reazione	Torque arm kit	Drehmomentstütze
214	Kit albero lento sporgente	Single output shaft kit	Abtriebswelle
215	Kit albero lento bisporgente	Double extended output shaft kit	Doppelvorstehende abtriebswelle
23.01	Manicotto	Coupling sleeve	Hülse
25.01	Albero uscita cavo	Hollow output shaft	Abtriebshohlwelle
299	Kit protezione albero uscita cavo	Output shaft protection kit	Schutzvorrichtung für abtriebswelle
30.01	Boccola di centraggio	Flanged bush	Zentrierungsbuchse
31.01	Rondella	Washer	Federring
31.02	Rondella	Washer	Federring

Codice	Descrizione	Description	Beschreibung
95.24	Cappellotto	Closed oilseal	Geschlossene oeldichtung
96.01	Ghiera autobloccante	Self-locking ring nut	Selbstsperrende nutmutter
96.05	Grano	Dowel	Stift
96.10	Linguetta	Key	Keil
96.11	Linguetta	Key	Keil
96.12	Linguetta	Key	Keil
96.13	Linguetta	Key	Keil
96.30	Rasamento	Shim adjustment	Ausgleichscheibe
96.31	Rasamento	Shim adjustment	Ausgleichscheibe
96.32	Rasamento	Shim adjustment	Ausgleichscheibe
96.34	Rasamento	Shim adjustment	Ausgleichscheibe
96.40	Seeger	Circlip	Seeger
96.50	Tappo	Plug	Schraube
96.51	Tappo livello olio	Level plug	Oelstandsschraube
96.52	Tappo di sfianto	Breather plug	Entlüftungsschraube
96.60	Vite fissaggio	Tightening screw	Befestigungsschraube
96.61	Vite fissaggio	Tightening screw	Befestigungsschraube
96.62	Vite fissaggio	Tightening screw	Befestigungsschraube
96.63	Vite fissaggio	Tightening screw	Befestigungsschraube
96.64	Vite fissaggio	Tightening screw	Befestigungsschraube
96.65	Vite fissaggio	Tightening screw	Befestigungsschraube
96.67	Vite fissaggio	Tightening screw	Befestigungsschraube
96.68	Vite fissaggio	Tightening screw	Befestigungsschraube

**TA..B - TC..B - TF..B - TA..C - TC..C - TF..C**

**Dispositivo antiritorno - *Backstop device* - Rücklaufsperr**

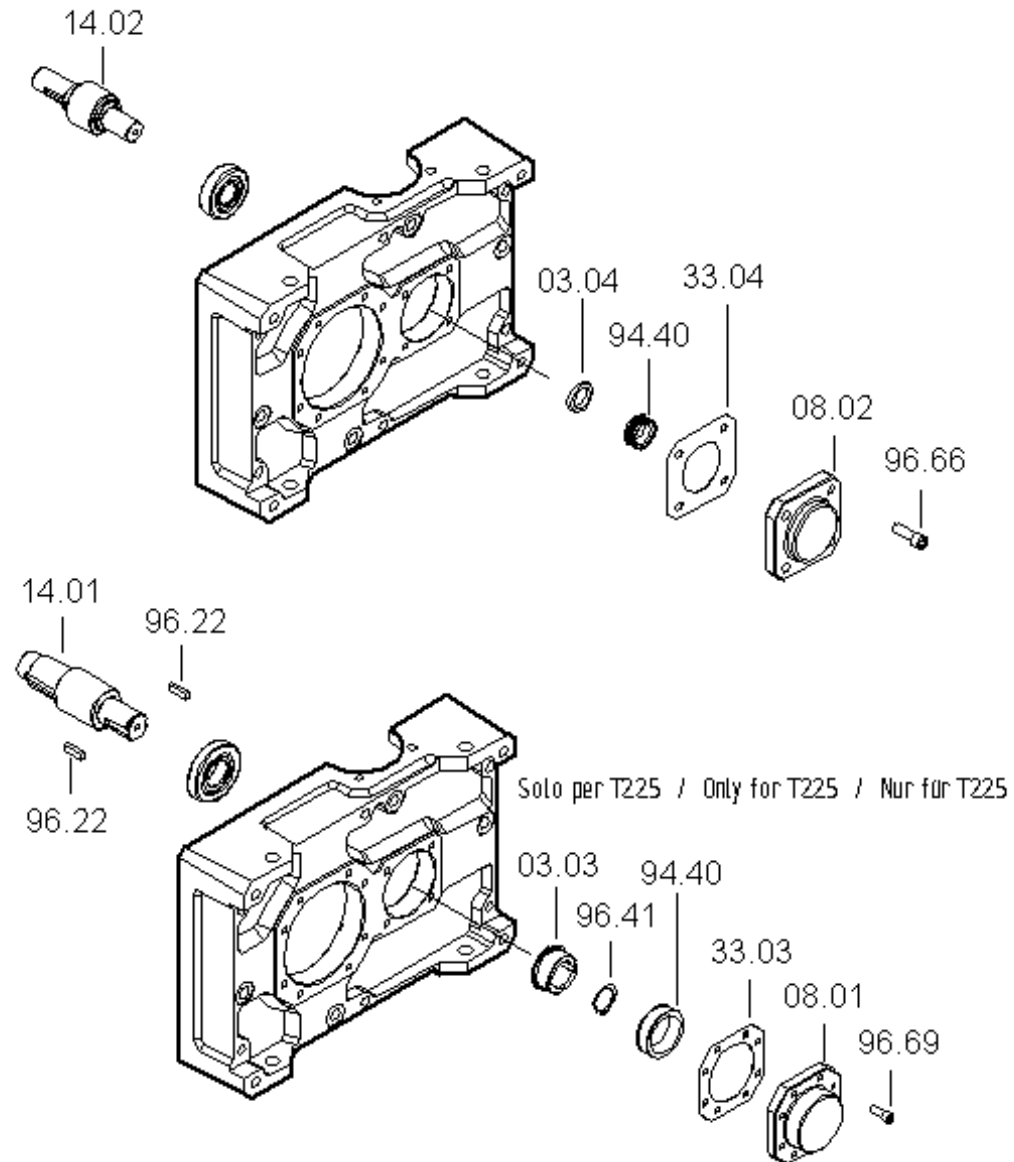



## TA..B - TC..B - TF..B - TA..C - TC..C - TF..C

TUTTI / ALL / ALLE			
Codice	Descrizione	Description	Beschreibung
03.04	Distanziale antiretro	<i>Back stop spacer</i>	Ruecklaufsperr distanzscheibe
08.02	Coperchio antiritorno	<i>Back stop cover</i>	Ruecklaufsperr deckel
14.02	Pignone antiritorno	<i>Backstop pinion</i>	Ruecklaufsperr ritzel
33.04	Guarnizione antiritorno	<i>Back stop gasket</i>	Ruecklaufsperr dichtung
96.66	Vite fissaggio	<i>Tightening</i>	Befestigungsschraube

SOLO T..225 / ONLY T..225 / NUR T..225			
Codice	Descrizione	Description	Beschreibung
03.03	Distanziale antiretro	<i>Back stop spacer</i>	Ruecklaufsperr distanzscheibe
08.01	Coperchio antiritorno	<i>Back stop cover</i>	Ruecklaufsperr deckel
14.01	Pignone antiritorno	<i>Backstop pinion</i>	Ruecklaufsperr ritzel
33.03	Guarnizione antiritorno	<i>Back stop gasket</i>	Ruecklaufsperr dichtung
96.41	Seeger	<i>Circlip</i>	Seeger
96.22	Linguetta	<i>Key</i>	Keil
96.69	Vite fissaggio	<i>Tightening</i>	Befestigungsschraube

T...B	Ruota libera / <i>Free wheel</i> / Freilauf 94.40
<b>71</b>	FE 423 Z
<b>90</b>	FE 428 Z
<b>112</b>	BF 50 Z 16
<b>140</b>	BF 70 Z 21
<b>180</b>	FE 8040 Z 19
<b>200</b>	FE 8054 Z 25
<b>225</b>	FE 8072 Z 25

T...C	Ruota libera / <i>Free wheel</i> / Freilauf 94.40
<b>80</b>	FE 423 Z
<b>100</b>	FE 428 Z
<b>125</b>	BF 50 Z 16
<b>160</b>	BF 70 Z 21
<b>180</b>	BF 70 Z 21
<b>200</b>	FE 8040 Z 19

# ZA..A

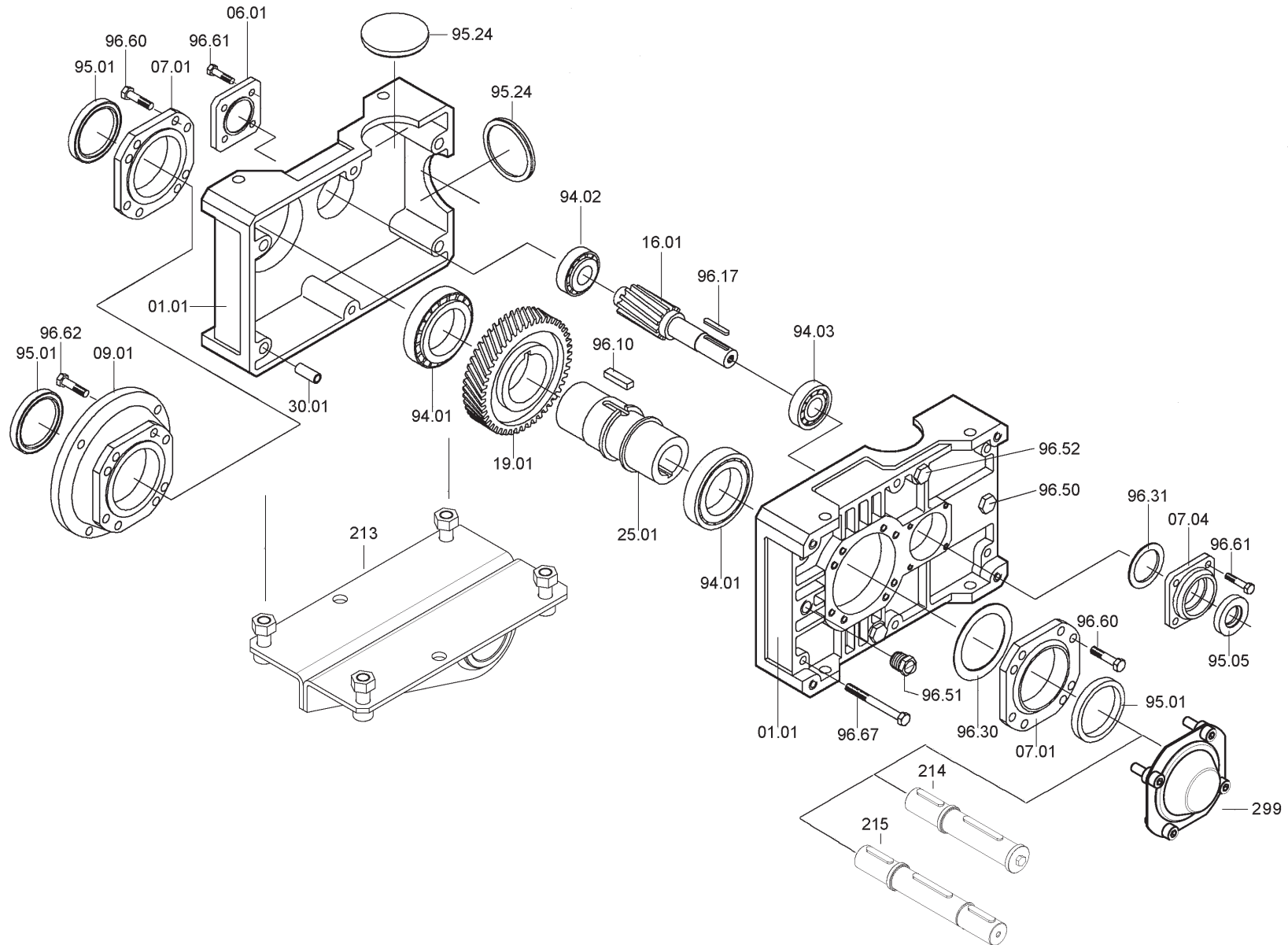



ZA	Cuscinetti / Bearings / Lager			Anelli di tenuta / Oilseals / Öldichtungen	
	94.01	94.02	94.03	95.01	95.05
<b>71A</b>	<b>32008</b> 40/68/19	<b>30302</b> 15/42/14.25	<b>32004</b> 20/42/15	40/56/8	20/35/7
<b>90A</b>	<b>32010</b> 50/80/20	<b>30204</b> 20/47/15.25	<b>32005</b> 25/47/15	50/65/8	25/47/7
<b>112A</b>	<b>32012</b> 60/95/23	<b>30305</b> 25/62/18.25	<b>30206</b> 30/62/17.25	60/80/10	30/52/7
<b>140A</b>	<b>32015</b> 75/115/25	<b>32206</b> 30/62/21.25	<b>32008</b> 40/68/19	75/95/10	40/56/8
<b>180A</b>	<b>32019</b> 95/145/32	<b>30307</b> 35/80/22.75	<b>(32208)*</b> (40/80/24.75)*	95/125/12	50/65/8
<b>225A</b>	<b>32026</b> 130/200/45	<b>31310</b> 50/110/29.25	<b>33113</b> 65/110/34	130/160/12	65/80/10

\* Presente solo nei rapporti in = 6.3 e 8 / Only for ratio in = 6.3 and 8 / Nur für untersetzung in = 6.3 und 8

Codice	Descrizione	Description	Beschreibung
01.01	Corpo	Housing	Gehäuse
06.01	Coperchio chiuso	Closed cover	Geschlossener deckel
07.01	Coperchio aperto	Open cover	Geöffneter deckel
07.04	Coperchio aperto	Open cover	Geöffneter deckel
09.01	Flangia uscita	Output flange	Abtriebsflansch
16.01	Albero pignone	Pinion shaft	Ritzel welle
19.01	Corona cilindrica uscita	Cyl.output wheel	Zyl.abtriebsrad
213	Kit braccio di reazione	Torque arm kit	Drehmomentstütze
214	Kit Albero lento sporgente	Single output extended shaft kit	Abtriebswelle
215	Albero lento bisporgente	Double extended output shaft	Doppelvorstehende abtriebswelle
25.01	Albero uscita cavo	Hollow output shaft	Abtriebshohlwelle
299	Kit protezione albero uscita cavo	Output shaft protection kit	Schutzvorrichtung für abtriebswelle
30.01	Boccola di centraggio	Flanged bush	Zentrierungsbuchse

Codice	Descrizione	Description	Beschreibung
95.24	Cappello	Closed oilseal	Geschlossene oeldichtung
96.10	Linguetta	Key	Keil
96.17	Linguetta	Key	Keil
96.30	Rasamento	Shim adjustment	Ausgleichscheibe
96.31	Rasamento	Shim adjustment	Ausgleichscheibe
96.50	Tappo	Plug	Schraube
96.51	Tappo livello olio	Level plug	Ölstandsschraube
96.52	Tappo di sfiato	Breather plug	Entlüftungsschraube
96.60	Vite fissaggio	Tightening screw	Befestigungsschraube
96.61	Vite fissaggio	Tightening screw	Befestigungsschraube
96.62	Vite fissaggio	Tightening screw	Befestigungsschraube
96.67	Vite fissaggio	Tightening screw	Befestigungsschraube

**ZA..B - ZF..B**

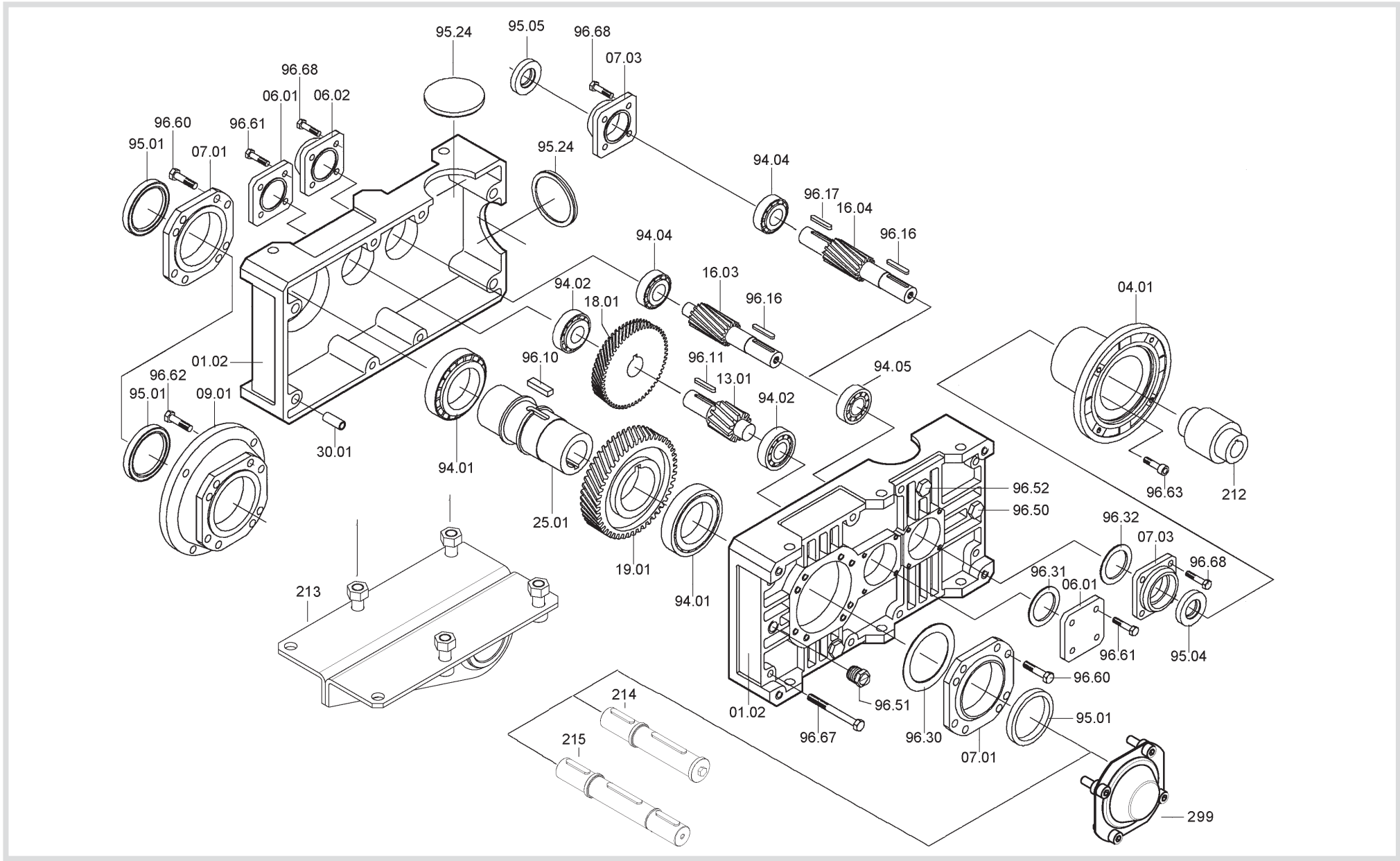



ZA - ZF	Cuscinetti / Bearings / Lager				Anelli di tenuta / Oilseals / Öldichtungen		
	94.01	94.02	94.04	94.05	95.01	95.04	95.05
<b>80B</b>	<b>32010</b> 50/80/20	<b>30204</b> 20/47/15.25	<b>30302</b> 15/42/14.25	<b>32004</b> 20/42/15	50/65/8	20/40/7	15/40/8
<b>100B</b>	<b>32012</b> 60/95/23	<b>30305</b> 25/62/18.25	<b>30204</b> 20/47/15.25	<b>32005</b> 25/47/15	60/80/10	25/47/7	20/47/7
<b>125B</b>	<b>32015</b> 75/115/25	<b>32206</b> 30/62/21.25	<b>30305</b> 25/62/18.25	<b>32026</b> 30/62/17.25	75/95/10	30/52/7	25/52/7
<b>160B</b>	<b>32019</b> 95/145/32	<b>32207</b> 35/72/24.25	<b>32206</b> 30/62/21.25	<b>32008</b> 40/68/19	95/125/12	40/56/8	30/56/10
<b>180B</b>	<b>32024</b> 120/180/38	<b>31309</b> 45/100/27.25	<b>30307</b> 35/80/22.75	<b>32208</b> 40/80/24.75	120/160/15	40/56/8	30/56/10
<b>200B</b>	<b>32026</b> 130/200/45	<b>31310</b> 50/110/29.25	<b>32208</b> 40/80/24.75	<b>32010</b> 50/80/20	130/160/12	50/65/8	40/65/10

Codice	Descrizione	Description	Beschreibung
01.02	Corpo	Housing	Gehäuse
04.01	Campana	Beel	Gloke
06.01	Coperchio chiuso	Closed cover	Geschlossener deckel
06.02	Coperchio chiuso	Closed cover	Geschlossener deckel
07.01	Coperchio aperto	Open cover	Geöffneter deckel
07.03	Coperchio aperto	Open cover	Geöffneter deckel
09.01	Flangia uscita	Output flange	Abtriebsflansch
13.01	Pignone cilindrico	Cylindrical pinion	Zyl.ritzel
16.03	Albero pignone	Pinion shaft	Ritzel welle
16.04	Albero pignone bisporgente	Double extended pinion shaft	Doppelvorstehende ritzel welle
18.01	Corona cilindrica intermedia	Intermediate cyl. wheel	Mittel zyl.rad
19.01	Corona cilindrica uscita	Cyl.output wheel	Zyl.abtriebsrad
212	Giunto	Coupling	Kupplung
213	Kit braccio di reazione	Torque arm kit	Drehmomentstütze
214	Kit albero lento sporgente	Single output extended shaft kit	Abtriebswelle
215	Kit albero lento bisporgente	Double extended output shaft kit	Doppelvorstehende abtriebswelle
25.01	Albero uscita cavo	Hollow output shaft	Abtriebshohlwelle
299	Kit protezione albero uscita cavo	Output shaft protection kit	Schutzvorrichtung für abtriebswelle
30.01	Boccola di centraggio	Flanged bush	Zentrierungsbuchse

Codice	Descrizione	Description	Beschreibung
95.24	Cappellotto	Closed oilseal	Geschlossene oeldichtung
96.10	Linguetta	Key	Keil
96.11	Linguetta	Key	Keil
96.16	Linguetta	Key	Keil
96.17	Linguetta	Key	Keil
96.30	Rasamento	Shim adjustment	Ausgleichscheibe
96.31	Rasamento	Shim adjustment	Ausgleichscheibe
96.32	Rasamento	Shim adjustment	Ausgleichscheibe
96.50	Tappo	Plug	Schraube
96.51	Tappo livello olio	Level plug	Oelstandsschraube
96.52	Tappo di sfiato	Breather plug	Entlüftungsschraube
96.60	Vite fissaggio	Tightening screw	Befestigungsschraube
96.61	Vite fissaggio	Tightening screw	Befestigungsschraube
96.62	Vite fissaggio	Tightening screw	Befestigungsschraube
96.63	Vite fissaggio	Tightening screw	Befestigungsschraube
96.67	Vite fissaggio	Tightening screw	Befestigungsschraube
96.68	Vite fissaggio	Tightening screw	Befestigungsschraube





ZA - ZF	Cuscinetti / Bearings / Lager				Anelli di tenuta / Oilseals / Öldichtungen			
	94.01	94.02	94.04	94.06	94.07	95.01	95.04	95.05
<b>80C</b>	<b>32010</b> 50/80/20	<b>30204</b> 20/47/15.25	<b>30302</b> 15/42/14.25	<b>3202</b> 15/35/15.9	<b>3202</b> 15/35/15.9	50/65/8	15/30/7	15/30/7
<b>100C</b>	<b>32012</b> 60/95/23	<b>30305</b> 25/62/18.25	<b>30204</b> 20/47/15.25	<b>30302</b> 15/42/14.25	<b>32004</b> 20/42/15	60/80/10	20/40/7	15/40/8
<b>125C</b>	<b>32015</b> 75/115/25	<b>32206</b> 30/62/21.25	<b>30305</b> 25/62/18.25	<b>30204</b> 20/47/15.25	<b>32005</b> 25/47/15	75/95/10	25/47/7	20/47/7
<b>160C</b>	<b>32019</b> 95/145/32	<b>32207</b> 35/72/24.25	<b>32206</b> 30/62/21.25	<b>30305</b> 25/62/18.25	<b>30206</b> 30/62/17.25	95/125/12	30/52/7	25/52/7
<b>180C</b>	<b>32024</b> 120/180/38	<b>31309</b> 45/100/27.25	<b>32206</b> 30/62/21.25	<b>30305</b> 25/62/18.25	<b>30206</b> 30/62/17.25	120/160/15	30/52/7	25/52/7
<b>200C</b>	<b>32026</b> 130/200/45	<b>31310</b> 50/110/29.25	<b>30307</b> 35/80/22.75	<b>32206</b> 30/62/21.25	<b>32008</b> 40/68/19	130/160/12	40/56/8	30/56/10

Codice	Descrizione	Description	Beschreibung
01.03	Corpo	Housing	Gehäuse
04.01	Campana	Beel	Gloke
06.01	Coperchio chiuso	Closed cover	Geschlossener deckel
06.02	Coperchio chiuso	Closed cover	Geschlossener deckel
06.03	Coperchio chiuso	Closed cover	Geschlossener deckel
07.01	Coperchio aperto	Open cover	Geöffneter deckel
07.02	Coperchio aperto	Open cover	Geöffneter deckel
09.01	Flangia uscita	Output flange	Abtriebsflansch
13.01	Pignone cilindrico	Cylindrical pinion	Zyl.ritzel
13.02	Pignone cilindrico	Cylindrical pinion	Zyl.ritzel
17.01	Albero pignone antiretro	Back stop pinion shaft	Ruecklaufsperr ritzel welle
17.02	Albero pignone antiretro bisporgente	Double extended Back stop pinion shaft	Doppelvorstehende Ruecklaufsperr ritzel welle
18.01	Corona cilindrica intermedia	Intermediate cyl. wheel	Mittel zyl.rad
18.02	Corona cilindrica intermedia	Intermediate cyl. wheel	Mittel zyl.rad
19.01	Corona cilindrica uscita	Cyl.output wheel	Zyl.abtriebsrad
212	Giunto	Coupling	Kupplung
213	Kit braccio di reazione	Torque arm kit	Drehmomentstütze
214	Kit albero lento sporgente	Single output extended shaft kit	Abtriebswelle
215	Kit albero lento bisporgente	Double extended output shaft kit	Doppelvorstehende abtriebswelle
25.01	Albero uscita cavo	Hollow output shaft	Abtriebshohlwelle
299	Kit protezione albero uscita cavo	Output shaft protection kit	Schutzvorrichtung für abtriebswelle
30.01	Boccola di centraggio	Flanged bush	Zentrierungsbuchse

Codice	Descrizione	Description	Beschreibung
95.24	Cappello	Closed oilseal	Geschlossene oeldichtung
96.10	Linguetta	Key	Keil
96.11	Linguetta	Key	Keil
96.12	Linguetta	Key	Keil
96.13	Linguetta	Key	Keil
96.14	Linguetta	Key	Keil
96.30	Rasamento	Shim adjustment	Ausgleichscheibe
96.31	Rasamento	Shim adjustment	Ausgleichscheibe
96.32	Rasamento	Shim adjustment	Ausgleichscheibe
96.33	Rasamento	Shim adjustment	Ausgleichscheibe
96.50	Tappo	Plug	Schraube
96.51	Tappo livello olio	Level plug	Oelstandsschraube
96.52	Tappo di sfianto	Breather plug	Entlüftungsschraube
96.60	Vite fissaggio	Tightening screw	Befestigungsschraube
96.61	Vite fissaggio	Tightening screw	Befestigungsschraube
96.62	Vite fissaggio	Tightening screw	Befestigungsschraube
96.63	Vite fissaggio	Tightening screw	Befestigungsschraube
96.67	Vite fissaggio	Tightening screw	Befestigungsschraube
96.68	Vite fissaggio	Tightening screw	Befestigungsschraube
96.69	Vite fissaggio	Tightening screw	Befestigungsschraube

**ZA..B - ZF..B - ZA..C - ZF..C**

**Dispositivo antiritorno - *Backstop device* - Rücklaufsperr**





## ZA..B - ZF..B - ZA..C - ZF..C

Codice	Descrizione	Description	Beschreibung
03.03	Distanziale antiretro	<i>back stop spacer</i>	Ruecklaufsperr distanzscheibe
08.01	Coperchio antiritorno	<i>Back stop cover</i>	Ruecklaufsperr deckel
33.03	Guarnizione antiritorno	<i>Back stop gasket</i>	Ruecklaufsperr dichtung
96.66	Vite fissaggio	<i>Tlghtening screw</i>	Befestigungsschraube

Z...B	Ruota libera / <i>Free wheel</i> / Freilaufad 94.40
<b>80</b>	FE 423 Z
<b>100</b>	FE 428 Z
<b>125</b>	BF 50 Z 16
<b>160</b>	BF 70 Z 21
<b>180</b>	FE 8040 Z 19
<b>200</b>	FE 8040 Z 19

Z...C	Ruota libera / <i>Free wheel</i> / Freilaufad 94.40
<b>80</b>	FE 423 Z2
<b>100</b>	FE 423 Z
<b>125</b>	FE 428 Z
<b>160</b>	BF 50 Z 16
<b>180</b>	BF 50 Z 16
<b>200</b>	BF 70 Z 21

PA..A

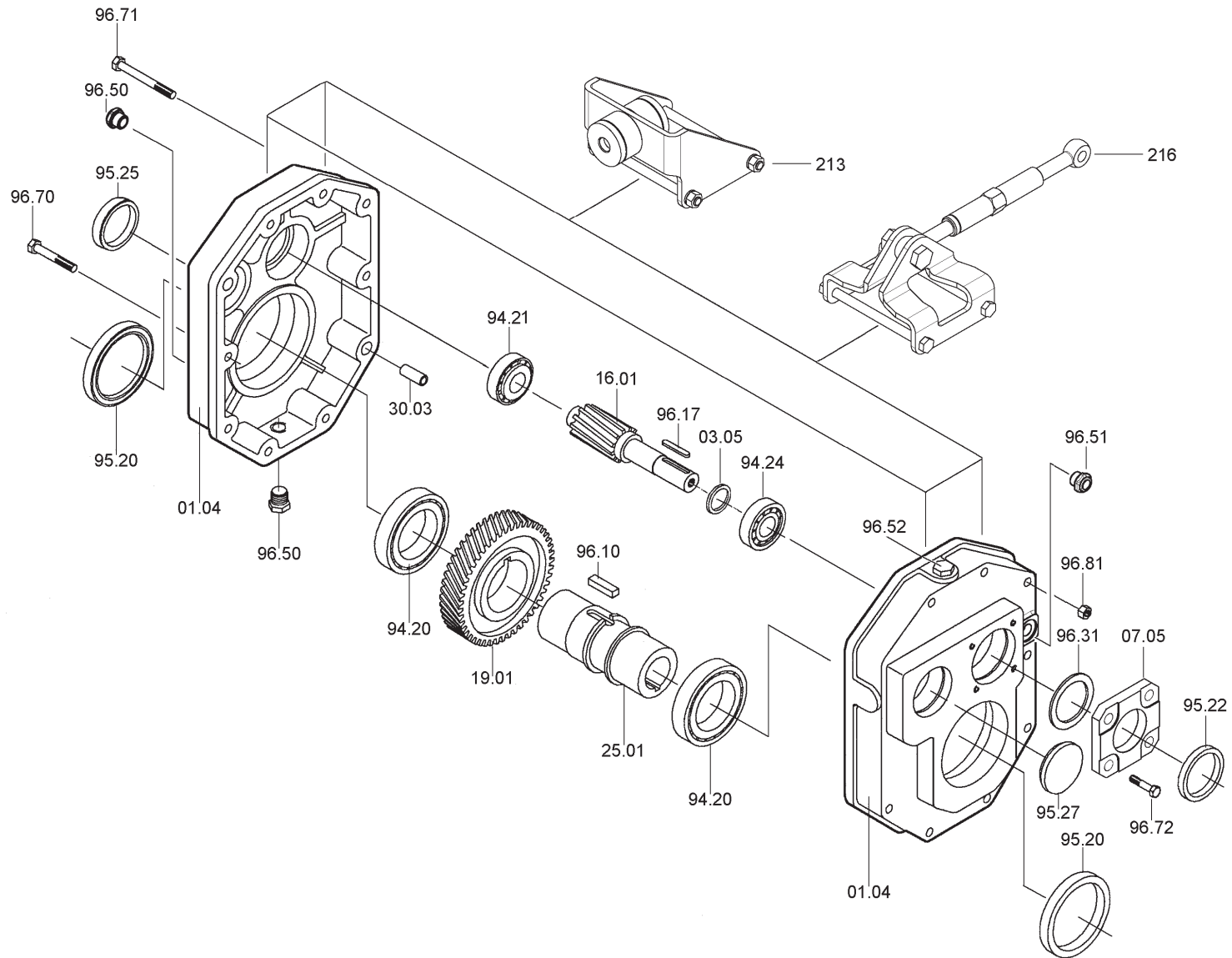



PA	Cuscinetti / Bearings / Lager			Anelli di tenuta / Oilseals / Öldichtungen	
	94.20	94.21	94.24	95.20	95.22
<b>63A</b>	<b>6008</b> 40/68/15	<b>30302</b> 15/42/14.25	<b>32004</b> 20/42/15	40/62/7	20/35/7
<b>80A</b>	6210 50/90/20	<b>30304</b> 20/52/16.25	<b>30205</b> 25/52/16.25	50/80/10	25/40/7
<b>100A</b>	<b>6212</b> 60/110/22	<b>30305</b> 25/62/18.25	<b>30206</b> 30/62/17.25	60/100/13	30/52/7
<b>125A</b>	<b>6215</b> 75/130/25	<b>30306</b> 30/72/20.75	<b>30208</b> 40/80/19.75	75/120/12	40/68/10
<b>160A</b>	<b>6219</b> 95/170/32	<b>32208</b> 40/80/24.75	<b>30210</b> 50/90/21.75	95/136/13	50/80/8

Codice	Descrizione	Description	Beschreibung
01.04	Corpo	<i>Housing</i>	Gehaeuse
03.05	Distanziale	<i>Spacer</i>	Distanzscheibe
07.05	Coperchio aperto	<i>Open cover</i>	Geoffneter deckel
16.01	Albero pignone	<i>Pinion shaft</i>	Ritzel Welle
19.01	Corona cilindrica uscita	<i>Cyl.output wheel</i>	Zyl.abtriebsrad
213	Kit braccio di reazione	<i>Torque arm kit</i>	Drehmomentstütze
216	Kit tirante	<i>Tension arm kit</i>	Spanner
25.01	Albero uscita cavo	<i>Hollow output shaft</i>	Abtriebshohlwelle
30.03	Boccola di centraggio	<i>Flanged bush</i>	Zentrierungsbuchse

Codice	Descrizione	Description	Beschreibung
95.25	Cappello	<i>Closed oilseal</i>	Geschlossene oeldichtung
95.27	Cappello	<i>Closed oilseal</i>	Geschlossene oeldichtung
96.10	Linguetta	<i>Key</i>	Keil
96.17	Linguetta	<i>Key</i>	Keil
96.31	Rasamento	<i>Shim adjustment</i>	Ausgleichscheibe
96.50	Tappo	<i>Plug</i>	Schraube
96.51	Tappo livello oil	<i>Level plug</i>	Oelstandschraube
96.52	Tappo di sfiato	<i>Breather plug</i>	Entlueftungsschraube
96.70	Vite fissaggio	<i>Tightening screw</i>	Befestigungsschraube
96.71	Vite fissaggio	<i>Tightening screw</i>	Befestigungsschraube
96.72	Vite fissaggio	<i>Tightening screw</i>	Befestigungsschraube
96.81	Dado	<i>Screw nut</i>	Schraubenmutter

**PA..B - PC..B**

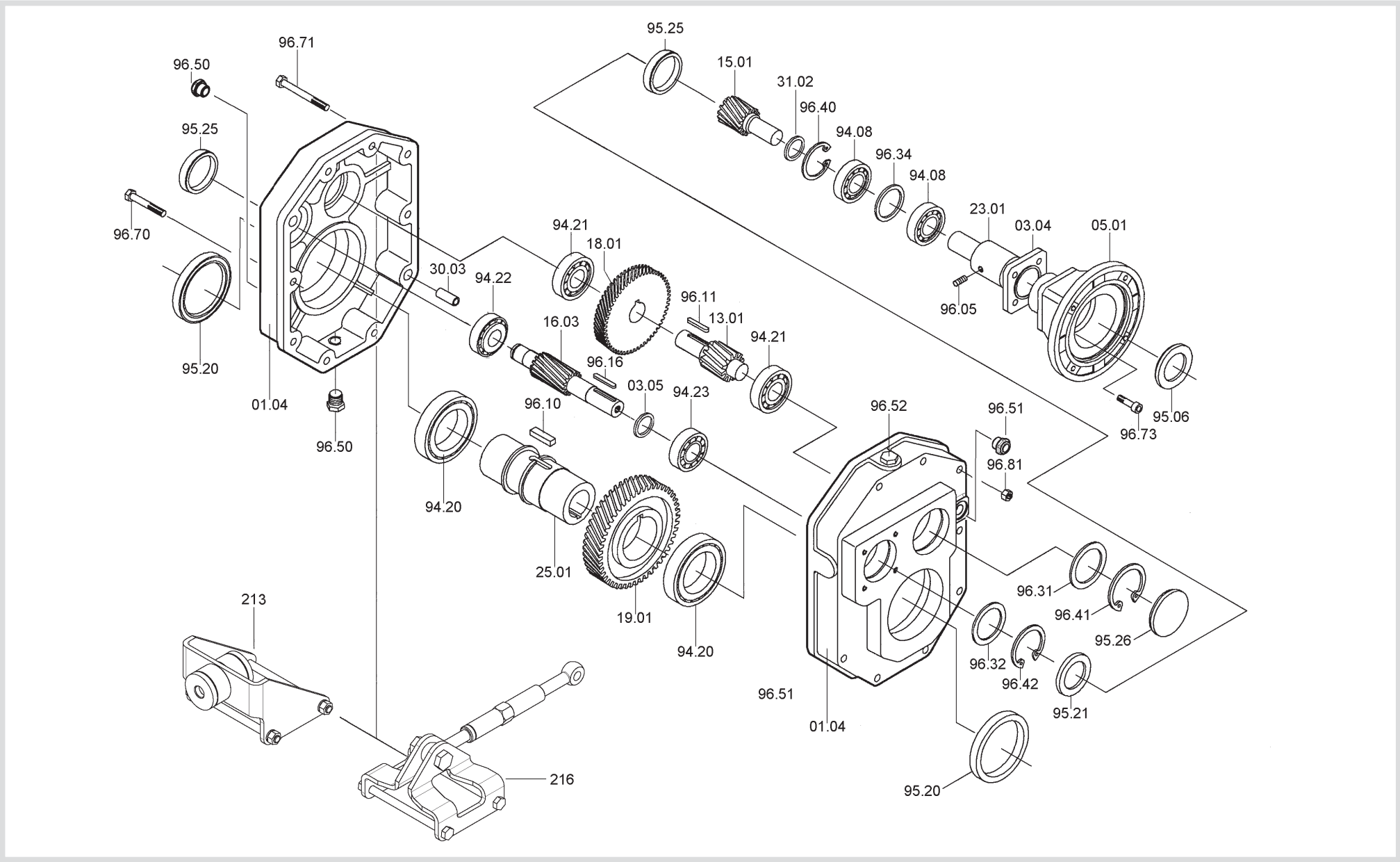



PA - PC	Cuscinetti / Bearings / Lager					Anelli di tenuta / Oilseals / Öldichtungen			
	PA - PC		PA		PC	PA - PC	PC		PA
	94.20	94.21	94.22	94.23	94.08	95.20	IEC	95.06	95.21
<b>63B</b>	6008 40/68/15	6302 15/45/13	6301 12/37/21	6302 15/42/13	7203 17/40/12	40/62/7	63	25/52/7	15/35/7
							71	30/52/7	
							80	35/52/7	
							90	37/52/7	
<b>80B</b>	6210 50/90/20	6304 20/52/15	30302 15/45/14.25	30204 20/47/15.25	7205 25/52/15	50/80/10	71 - 80	35/62/7	20/47/7
							90	40/62/8	
							100 - 112	45/62/8	
<b>100B</b>	6212 60/110/22	6305 25/62/17	30304 20/52/16.25	30205 25/52/16.25	7206 30/62/16	60/100/13	80 - 90	40/72/10	25/52/7
							100 - 112	45/72/8	
							132	55/72/10	
<b>125B</b>	6215 75/130/25	6306 30/72/19	30305 25/62/18.25	30206 30/62/17.25	7207 35/72/17	75/120/12	80 - 90	45/80/10	30/62/7
							100 - 112	45/80/10	
							132	55/80/10	
							160	60/80/10	
<b>160B</b>	6219 95/170/32	6307 35/80/21	30306 30/72/20.75	30208 40/80/19.75	7209 45/85/38	95/136/13	100 - 112	55/100/10	40/80/10
							132 - 160	60/100/10	
							180	65/100/10	
							200	75/100/10	

Codice	Descrizione	Description	Beschreibung
01.04	Corpo	Housing	Gehaeuse
03.04	Distanziale	Spacer	Distanzscheibe
03.05	Distanziale	Spacer	Distanzscheibe
05.01	Flangia	Flange	Flansch
13.01	Pignone cilindrico	Cylindrical pinion	Zyl.ritzel
15.01	Pignone cilindrico	Cylindrical pinion	Zyl.ritzel
16.03	Albero pignone	Pinion shaft	Ritzel welle
18.01	Corona cilindrica intermedia	Intermediate cyl. wheel	Mittel zyl.rad
19.01	Corona cilindrica uscita	Cyl.output wheel	Zyl.abtriebsrad
213	Kit braccio di reazione	Torque arm kit	Drehmomentstütze
216	Kit tirante	Tension arm kit	Spanner
23.01	Manicotto	Coupling sleeve	Hülse
25.01	Albero uscita cavo	Hollow output shaft	Abtriebshohlwelle
30.03	Boccola di centraggio	Flanged bush	Zentrierungsbuchse
31.02	Rondella	Washer	Federring
95.25	Cappello	Closed oilseal	Geschlossene oeldichtung
95.26	Cappello	Closed oilseal	Geschlossene oeldichtung

Codice	Descrizione	Description	Beschreibung
96.05	Grano	Dowel	stift
96.10	Linguetta	Key	Keil
96.11	Linguetta	Key	Keil
96.16	Linguetta	Key	Keil
96.31	Rasamento	Shim adjustment	Ausgleichscheibe
96.32	Rasamento	Shim adjustment	Ausgleichscheibe
96.34	Rasamento	Shim adjustment	Ausgleichscheibe
96.40	Seeger	Circlip	Seeger
96.41	Seeger	Circlip	Seeger
96.42	Seeger	Circlip	Seeger
96.50	Tappo	Plug	Schraube
96.51	Tappo livello oil	Level plug	Oelstandschrabe
96.52	Tappo di sfiato	Breather plug	Entlueftungsschraube
96.70	Vite fissaggio	Tightening screw	Befestigungsschraube
96.71	Vite fissaggio	Tightening screw	Befestigungsschraube
96.73	Vite fissaggio	Tightening screw	Befestigungsschraube
96.81	Dado	Screw nut	Schraubenmutter

**PA..B**

**Dispositivo antiritorno - *Backstop device* - Rücklaufsperre**

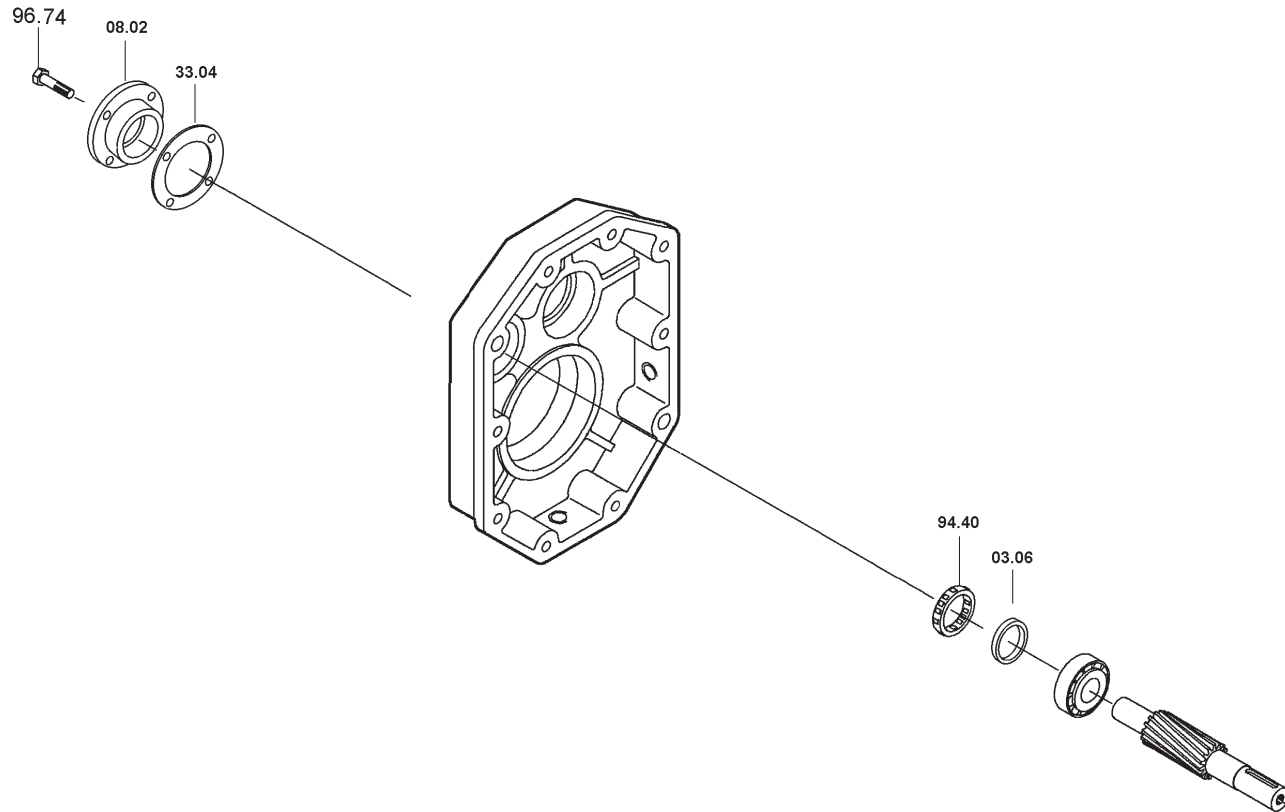



<b>P</b>	Ruota libera / Free wheel / Freilauftrad <b>94.40</b>
<b>63</b>	NSS 12
<b>80</b>	FE 423 Z
<b>100</b>	FE 428 Z
<b>125</b>	BF 50 Z 16
<b>160</b>	BF 70 Z 21

<b>Codice</b>	<b>Descrizione</b>	<b>Description</b>	<b>Beschreibung</b>
03.06	Distanziale antiretro	<i>Back stop spacer</i>	Ruecklaufsperr distanzscheibe
08.02	Coperchio antiritorno	<i>back stop cover</i>	Ruecklaufsperr deckel
33.04	Guarnizione antiritorno	<i>Back stop gasket</i>	Ruecklaufsperr dichtung
96.74	Vite fissaggio	<i>Tightening screw</i>	Befestigungsschraube

**MA..B**

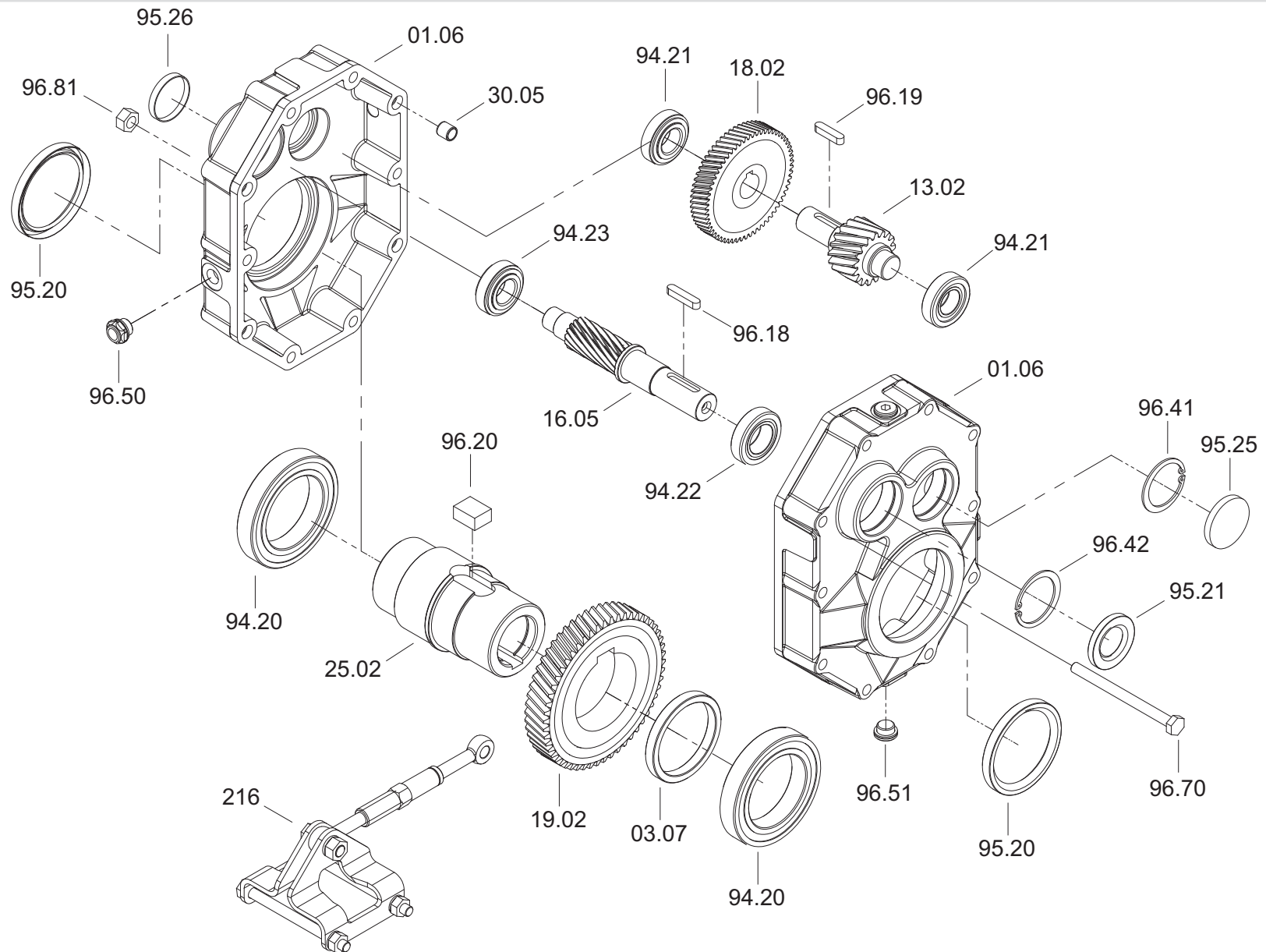



MA	Cuscinetti / Bearings / Lager				Anelli di tenuta / Oilseals / Öldichtungen	
	94.20	94.21	94.22	94.23	95.20	95.21
<b>63B</b>	<b>6010</b> 50/80/16	<b>6303</b> 17/47/14	<b>6004</b> 20/42/12	<b>6203</b> 17/40/12	50/65/8	<b>20/42/7</b>
<b>80B</b>	<b>6012</b> 60/95/18	<b>30204</b> 20/47/15.25	<b>6205</b> 25/52/15	<b>6204</b> 20/47/14	60/75/8	<b>25/52/7</b>
<b>100B</b>	<b>6015</b> 75/115/20	<b>30205</b> 25/52/16.25	<b>32006</b> 30/55/17	<b>30205</b> 25/52/16.25	75/95/10	<b>30/55/7</b>
<b>125B</b>	<b>6018</b> 90/140/24	<b>30206</b> 30/62/17.25	<b>32008</b> 40/68/19	<b>30206</b> 30/62/17.25	90/110/12	<b>40/68/10</b>
<b>140B</b>	<b>6219</b> 95/170/32	<b>30207</b> 35/72/18.25	<b>30208</b> 40/80/19.75	<b>30207</b> 35/72/18.25	95/125/12	<b>40/80/10</b>
<b>160B</b>	<b>6222</b> 110/200/38	<b>32208</b> 40/80/24.75	<b>32209</b> 45/85/24.75	<b>32208</b> 40/80/24.75	110/130/12	<b>45/85/10</b>
<b>180B</b>	<b>6226</b> 130/230/40	<b>33210</b> 50/90/32	<b>32210</b> 50/90/24.75	<b>32209</b> 45/85/24.75	130/160/12	<b>50/90/10</b>

Codice	Descrizione	Description	Beschreibung
01.06	Corpo	Housing	Gehaeuse
03.07	Distanziale	Spacer	Distanzscheibe
06.05	Coperchio	Cover	Deckel
13.02	Pignone cilindrico	Cylindrical pinion	Zyl.ritzel
16.05	Albero pignone	Pinion shaft	Ritzel Welle
18.02	Corona cilindrica intermedia	Intermediate cyl. wheel	Mittel zyl.rad
19.02	Corona cilindrica uscita	Cyl.output wheel	Zyl.abtriebsrad
25.02	Albero uscita cavo	Hollow output shaft	Abtriebshohlwelle
30.05	Boccola di centraggio	Flanged bush	Zentrierungsbuchse
95.25	Cappellotto	Closed oilseal	Geschlossene oeldichtung
95.26	Cappellotto	Closed oilseal	Geschlossene oeldichtung
96.18	Linguetta	Key	Keil
96.19	Linguetta	Key	Keil
96.20	Linguetta	Key	Keil
96.41	Seeger	Circlip	Seeger
96.42	Seeger	Circlip	Seeger
96.50	Tappo livello oil	Plug	Schraube
96.51	Tappo	Level plug	Ölstandschraube
96.52	Tappo di sfiato	Breather plug	Entlüftungsschraube
96.70	Vite fissaggio	Tightening screw	Befestigungsschraube
96.81	Dado	Screw nut	Schraubenmutter

## MA..B (antiretro)

### Dispositivo antiritorno - *Backstop device* - Rücklaufsperr

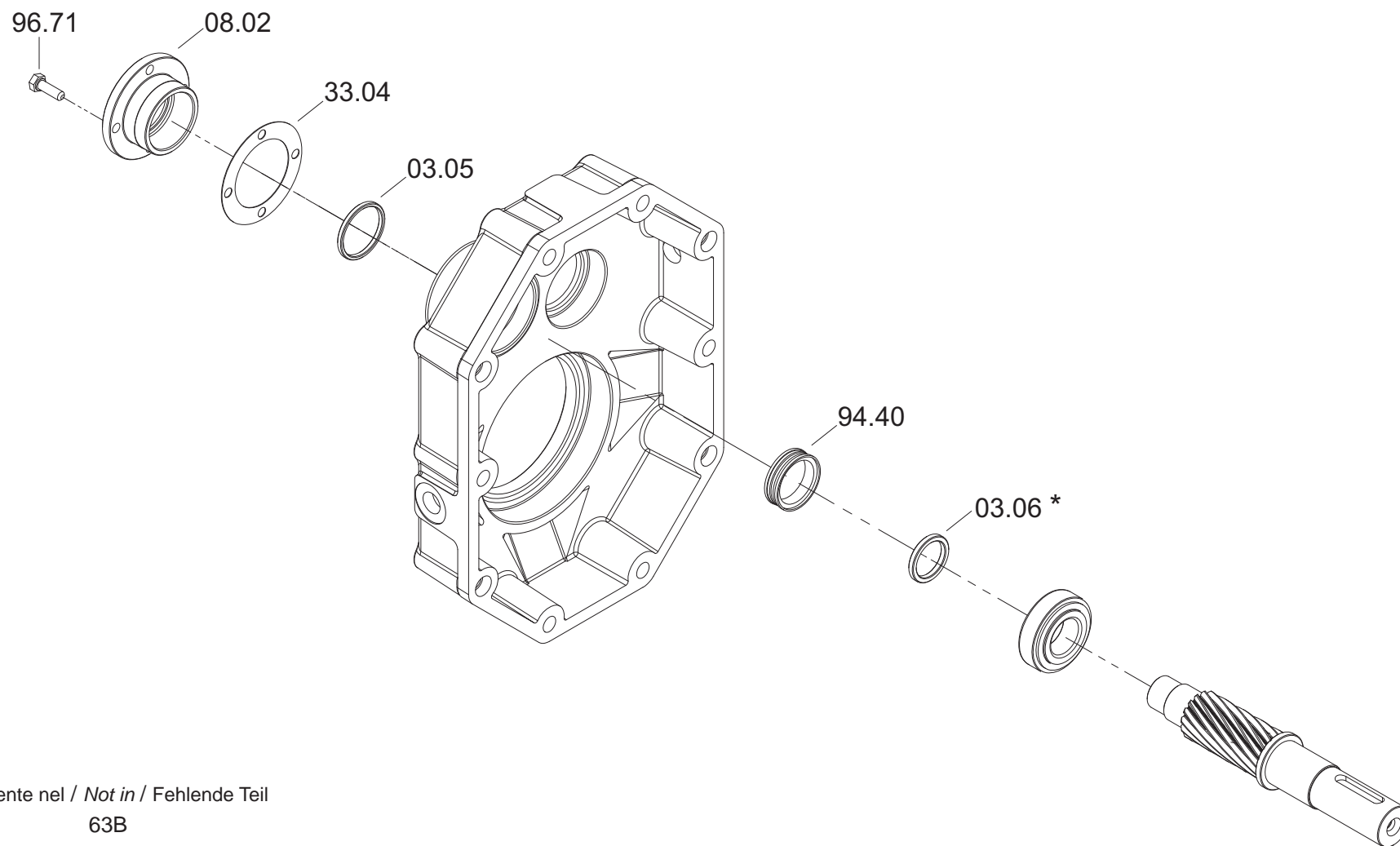

\* Assente nel / *Not in* / Fehlende Teil

63B

80B



<b>M</b>	Ruota libera / Free wheel / Freilauftrad <b>94.40</b>
<b>63B</b>	FE 423 Z
<b>80B</b>	FE 428 Z
<b>100B</b>	BF 50 Z 16
<b>125B</b>	BF 71 Z 16
<b>140B</b>	SF 31-13,5/12J
<b>160B</b>	BF 90 Z 21
<b>180B</b>	FE 8044 Z 19

<b>Codice</b>	<b>Descrizione</b>	<b>Description</b>	<b>Beschreibung</b>
03.05 03.06*	Distanziale	<i>Spacer</i>	Distanzscheibe
08.02	Coperchio antiritorno	<i>back stop cover</i>	Ruecklaufsperrdeckel
33.04	Guarnizione antiritorno	<i>Back stop gasket</i>	Ruecklaufsperrichtung
96.71	Vite fissaggio	<i>Tightening screw</i>	Befestigungsschraube

\* Assente nel / *Not in* / Fehlende Teil

63B

80B

**RA - RC - RF (in = 1)**

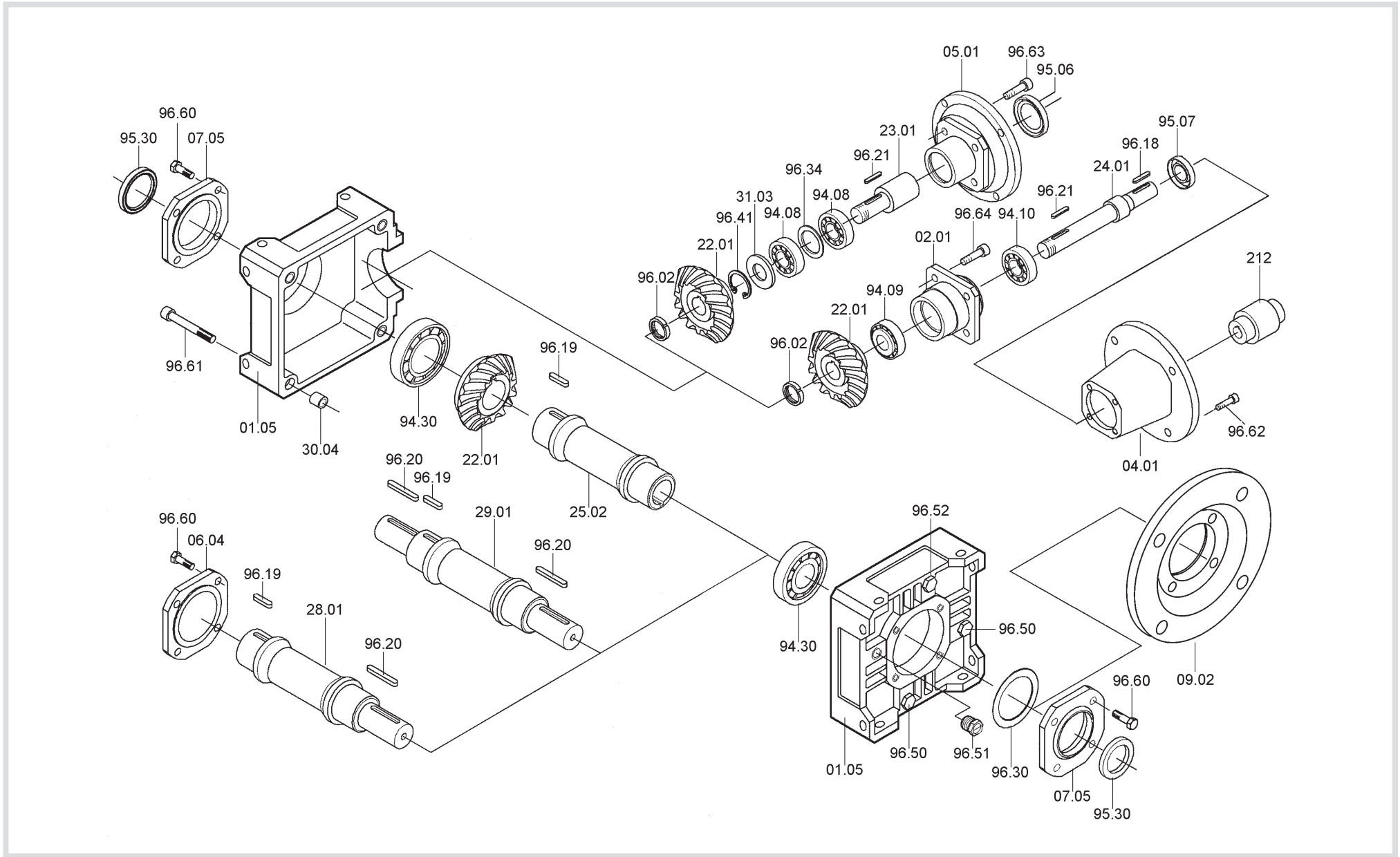



RA - RC - RF in = 1:1	Cuscinetti / Bearings / Lager			Anelli di tenuta / Oilseals / Öldichtungen			
	RA - RC - RF	RA - RF	RC	RA - RC - RF	RC		RA - RF
	94.30	94.10 - 94.09	94.08	95.30	IEC	95.06	95.07
19	6206 30/62/16	30203 20/40/13.25	7203 17/40/12	30/47/7	63	25/52/7	20/40/7
					71	30/52/7	
					80	35/52/7	
					90	37/52/7	
24	6207 35/72/17	32005 25/47/15	7205 25/52/15	35/52/7	71 - 80	35/62/7	30/47/7
					90	40/62/8	
					100 - 112	45/62/8	
28	6208 40/80/19	32006 30/55/17	7206 30/62/16	40/62/8	80 - 90	40/72/10	35/58/10
					100 - 112	45/72/8	
					132	55/72/10	
38	6211 55/100/21	32007 35/62/18	7207 35/72/17	55/72/10	80 - 90	45/80/10	40/62/10
					100 - 112	45/80/10	
					132	55/80/10	
					160	60/80/10	
48	6213 65/120/23	32009 45/75/20	—	65/90/10	—	—	55/80/10
					180	65/80/10	

Codice	Descrizione	Description	Beschreibung
01.05	Corpo	Housing	Gehäuse
02.01	Mozzo entrata	Ball-bearing hub	Antriebsnabe
04.01	Campana	Bell	Gloke
05.01	Flangia	Flange	Flansch
06.04	Coperchio chiuso	Closed cover	Geschlossener deckel
07.05	Coperchio aperto	Open cover	Geöffneter deckel
09.02	Flangia uscita	Output flange	Abtriebsflansch
212	Giunto	Coupling	Kupplung
22.01	Coppia conica rinvio	Bevel gear for right angle gearbox	Kegelrad fuer winkelgetriebe
23.01	Manicotto	Coupling sleeve	Verbindungswelle
24.01	Albero veloce	Input shaft	Antriebswelle
25.02	Albero uscita cavo	Hollow output shaft	Abtriebshohlwelle
28.01	Albero lento sporgente	Single output extended shaft	Abtriebswelle
29.01	Albero lento bisporgente	Double extended output shaft	Doppelvorstehende abtriebswelle
30.04	Boccola di centraggio	Flanged bush	Zentrierungsbuchse
31.03	Rondella	Washer	Federring

Codice	Descrizione	Description	Beschreibung
96.02	Ghiera autobloccante	Self-locking ring nut	Selbstsperrende nutmutter
96.18	Linguetta	Key	Keil
96.19	Linguetta	Key	Keil
96.20	Linguetta	Key	Keil
96.21	Linguetta	Key	Keil
96.30	Rasamento	Shim adjustment	Ausgleichscheibe
96.34	Rasamento	Shim adjustment	Ausgleichscheibe
96.41	Seeger	Circlip	Seeger
96.50	Tappo	Plug	Schraube
96.51	Tappo livello olio	Level plug	Ölstands-schraube
96.52	Tappo di sfato	Breather plug	Entlüftungsschraube
96.60	Vite fissaggio	Tightening screw	Befestigungsschraube
96.61	Vite fissaggio	Tightening screw	Befestigungsschraube
96.62	Vite fissaggio	Tightening screw	Befestigungsschraube
96.63	Vite fissaggio	Tightening screw	Befestigungsschraube
96.64	Vite fissaggio	Tightening screw	Befestigungsschraube





RA - RC - RF in > 1	Cuscinetti / Bearings / Lager				Anelli di tenuta / Oilseals / Öldichtungen				
	RA - RC - RF	RA - RF		RC	RA - RC - RF		RC		RA - RF
	94.30	94.09	94.10	94.08	95.30	95.31	IEC	95.06	95.07
19	6305 25/62/17	30203 20/40/13.25		7203 17/40/12	25/47/7	17/47/7	63	25/52/7	15/40/10
							71	30/52/7	
							80	35/52/7	
							90	37/52/7	
24	6306 30/72/19	32005 25/52/15		7205 25/52/15	30/52/7	20/52/7	71 - 80	35/62/7	20/47/7
							90	40/62/8	
							100 - 112	45/62/8	
28	6307 35/80/21	32006 30/55/17		7206 30/62/16	35/62/7	25/62/10	80 - 90	40/72/10	25/58/10
							100 - 112	45/72/8	
							132	55/72/10	
38	6309 45/100/25	32007 35/62/18		7207 35/72/17	45/72/8	30/72/10	80 - 90	45/80/10	30/62/7
							100 - 112	45/80/10	
							132	55/80/10	
							160	60/80/10	
48	6311 55/120/29	32009 45/75/20		7209 45/85/19	55/90/10	40/90/12	132 - 160	60/100/10	40/80/10
							180	65/100/10	
							200	75/100/10	

Codice	Descrizione	Description	Beschreibung
01.05	Corpo	Housing	Gehäuse
02.01	Mozzo entrata	Ball-bearing hub	Antriebsnabe
03.01	Distanziale	Spacer	Distanzscheibe
03.03	Distanziale	Spacer	Distanzscheibe
04.01	Campana	Bell	Glocke
05.01	Flangia	Flange	Flansch
06.04	Coperchio chiuso	Closed cover	Geschlossener deckel
07.05	Coperchio aperto	Open cover	Geöffneter deckel
09.02	Flangia uscita	Output flange	Abtriebsflansch
20.01	Coppia conica	Bevel gear	kegelrad
21.01	Coppia conica	Bevel gear	kegelrad
212	Giunto	Coupling	Kupplung
23.01	Manicotto	Coupling sleeve	Hülse
28.02	Albero lento int. sporgente	Intermediate extended shaft	Mittel vorstehendeabtriebswelle
29.02	Albero lento int. sporgente	Intermediate extended shaft	Mittel vorstehendeabtriebswelle
30.04	Boccola di centraggio	Flanged bush	Zentrierungsbuchse
30.05	Boccola	Bush	Buchse

Codice	Descrizione	Description	Beschreibung
31.02	Rondella	Washer	Federring
96.01	Ghiera autobloccante	Self-locking ring nut	Selbstsperrende nutmutter
96.05	Grano	Dowel	Stift
96.22	Linguetta	Key	Keil
96.23	Linguetta	Key	Keil
96.24	Linguetta	Key	Keil
96.30	Rasamento	Shim adjustment	Ausgleichscheibe
96.34	Rasamento	Shim adjustment	Ausgleichscheibe
96.40	Seeger	Circlip	Seeger
96.50	Tappo	Plug	Schraube
96.51	Tappo livello olio	Level plug	Oelstandschrabe
96.52	Tappo di sfiato	Breather plug	Entlueftungsschraube
96.60	Vite fissaggio	Tightening screw	Befestigungsschraube
96.61	Vite fissaggio	Tightening screw	Befestigungsschraube
96.62	Vite fissaggio	Tightening screw	Befestigungsschraube
96.63	Vite fissaggio	Tightening screw	Befestigungsschraube
96.64	Vite fissaggio	Tightening screw	Befestigungsschraube

**RA - RC - RF (in = 1) s.e.**

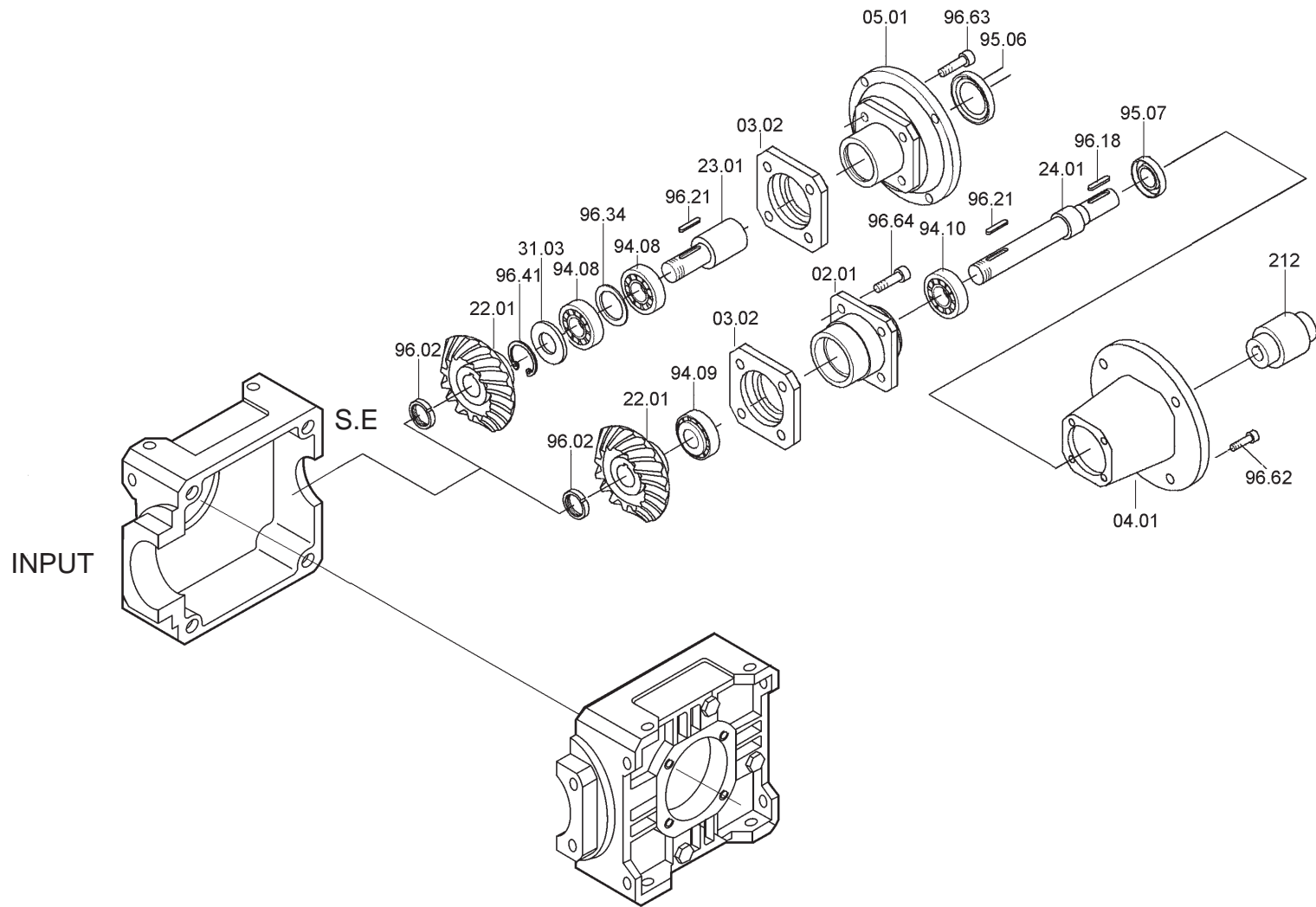



RA - RC - RF in = 1:1 S.E	Cuscinetti / Bearings / Lager		Anelli di tenuta / Oilseals / Öldichtungen		
	RA - RF	RC	RC		RA - RF
	94.10 - 94.09	94.08	IEC	95.06	95.07
19	30203 20/40/13.25	7203 17/40/12	63	25/52/7	20/40/7
			71	30/52/7	
			80	35/52/7	
			90	37/52/7	
24	32005 25/47/15	7205 25/52/15	71 - 80	35/62/7	30/47/7
			90	40/62/8	
			100 - 112	45/62/8	
28	32006 30/55/17	7206 30/62/16	80 - 90	40/72/10	35/58/10
			100 - 112	45/72/8	
			132	55/72/10	
38	32007 35/62/18	7207 35/72/17	80 - 90	45/80/10	40/62/7
			100 - 112	45/80/10	
			132	55/80/10	
			160	60/80/10	
48	32009 45/75/20	—	180	65/80/10	55/80/10
			—	—	

Codice	Descrizione	Description	Beschreibung
02.01	Mozzo entrata	Ball-bearing hub	Antriebsnabe
03.02	Distanziale SE	Spacer SE	Distanzscheibe SE
04.01	Campana	Bell	Gloke
05.01	Flangia	Flange	Flansch
212	Giunto	Coupling	Kupplung
22.01	Terna conica rinvio	Set of 3 bevel gear for right angle gearbox	3-St. Kegelradge triebe fur Winkelgetriebe
23.01	Manicotto	Coupling sleeve	Verbindungswelle
24.01	Albero veloce	Input shaft	Antriebswelle
31.03	Rondella	Washer	Federring

Codice	Descrizione	Description	Beschreibung
96.02	Ghiera autobloccante	Self-locking ring nut	Selbstsperrende nutmutter
96.18	Linguetta	Key	Keil
96.21	Linguetta	Key	Keil
96.34	Rasamento	Shim adjustment	Ausgleichscheibe
96.41	Seeger	Circlip	Seeger
96.62	Vite fissaggio	Tightening screw	Befestigungsschraube
96.63	Vite fissaggio	Tightening screw	Befestigungsschraube

**RA - RC - RF (in > 1) s.e.**

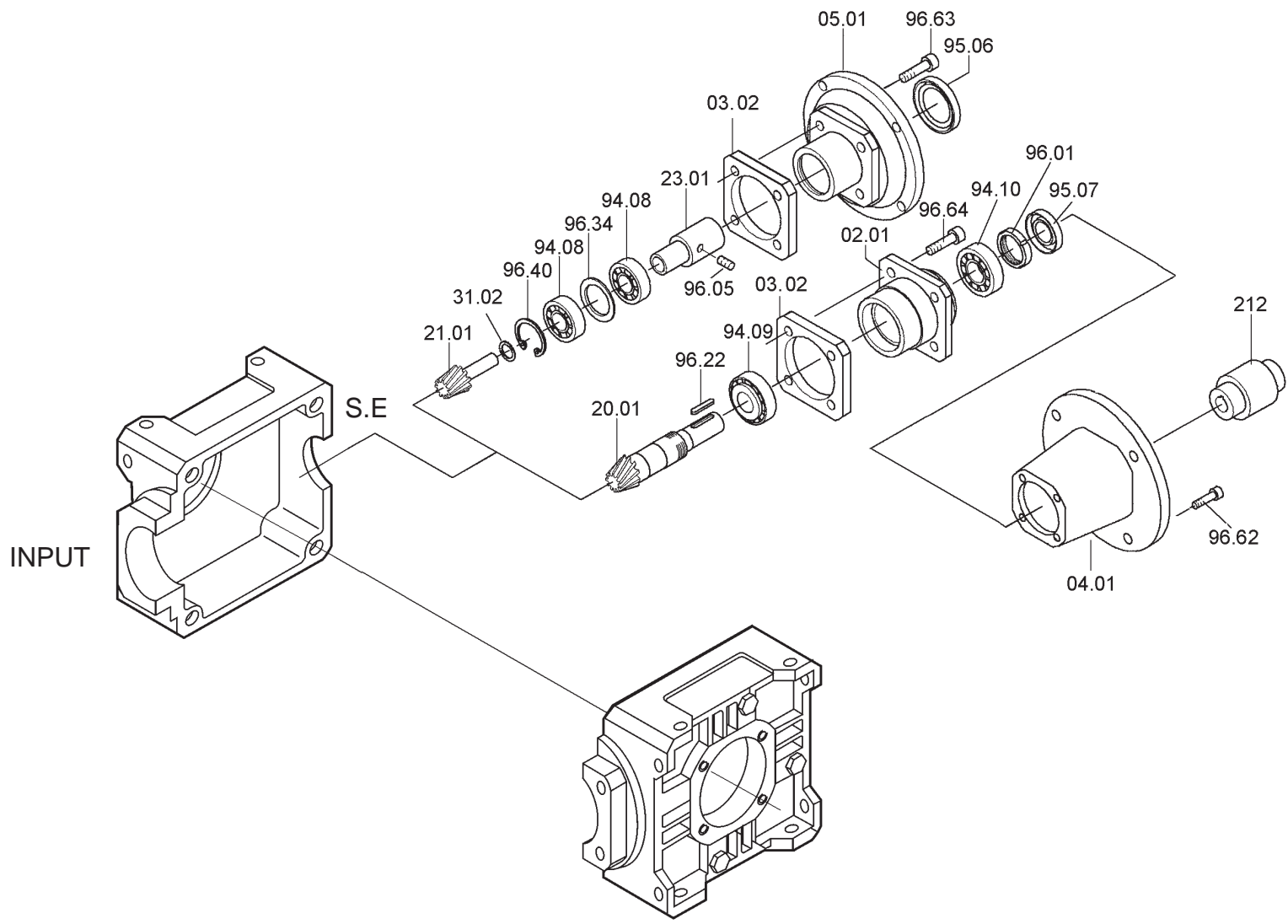



RA - RC - RF in = 1:1 S.E	Cuscinetti / Bearings / Lager		Anelli di tenuta / Oilseals / Öldichtungen		
	RA - RF	RC	RC		RA - RF
	94.09 - 94.10	94.08	IEC	95.06	95.07
19	30203 20/40/13.25	7203 17/40/12	63	25/52/7	15/40/10
			71	30/52/7	
			80	35/52/7	
			90	37/52/7	
24	32005 25/47/15	7205 25/52/15	71 - 80	35/62/7	20/47/7
			90	40/62/8	
			100 - 112	45/62/8	
28	32006 30/55/17	7206 30/62/16	80 - 90	40/72/10	25/58/10
			100 - 121	45/72/8	
			132	55/72/10	
38	32007 35/62/18	7207 35/72/17	80 - 90	45/80/10	30/62/10
			100 - 112	45/80/10	
			132	55/80/10	
			160	60/80/10	
48	32009 45/75/20	7209 45/85/19	180	65/80/10	40/80/10
			132 - 160	60/100/10	
			200	75/100/10	

Codice	Descrizione	Description	Beschreibung
02.01	Mozzo entrata	Ball-bearing hub	Antriebsnabe
03.02	Distanziale SE	Spacer SE	Distanzscheibe SE
04.01	Campana	Bell	Gloke
05.01	Flangia	Flange	Flansch
20.01	Terna conica	Set of 3 bevel gear	3-St. Kegelaradge triebe
21.01	Terna conica	Set of 3 bevel gear	3-St. Kegelaradge triebe
212	Giunto	Coupling	Kupplung
23.01	Manicotto	Coupling sleeve	Verbindungswelle

Codice	Descrizione	Description	Beschreibung
31.02	Rondella	Washer	Federring
96.01	Ghiera autobloccante	Self-locking ring nut	Selbstsperrende
96.05	Grano	Dowel	Stift
96.22	Linguetta	Key	Keil
96.34	Rasamento	Shim adjustment	Ausgleichscheibe
96.40	Seeger	Circlip	Seeger
96.62	Vite fissaggio	Tightening screw	Befestigungsschraube
96.63	Vite fissaggio	Tightening screw	Befestigungsschraube
96.64	Vite fissaggio	Tightening screw	Befestigungsschraube

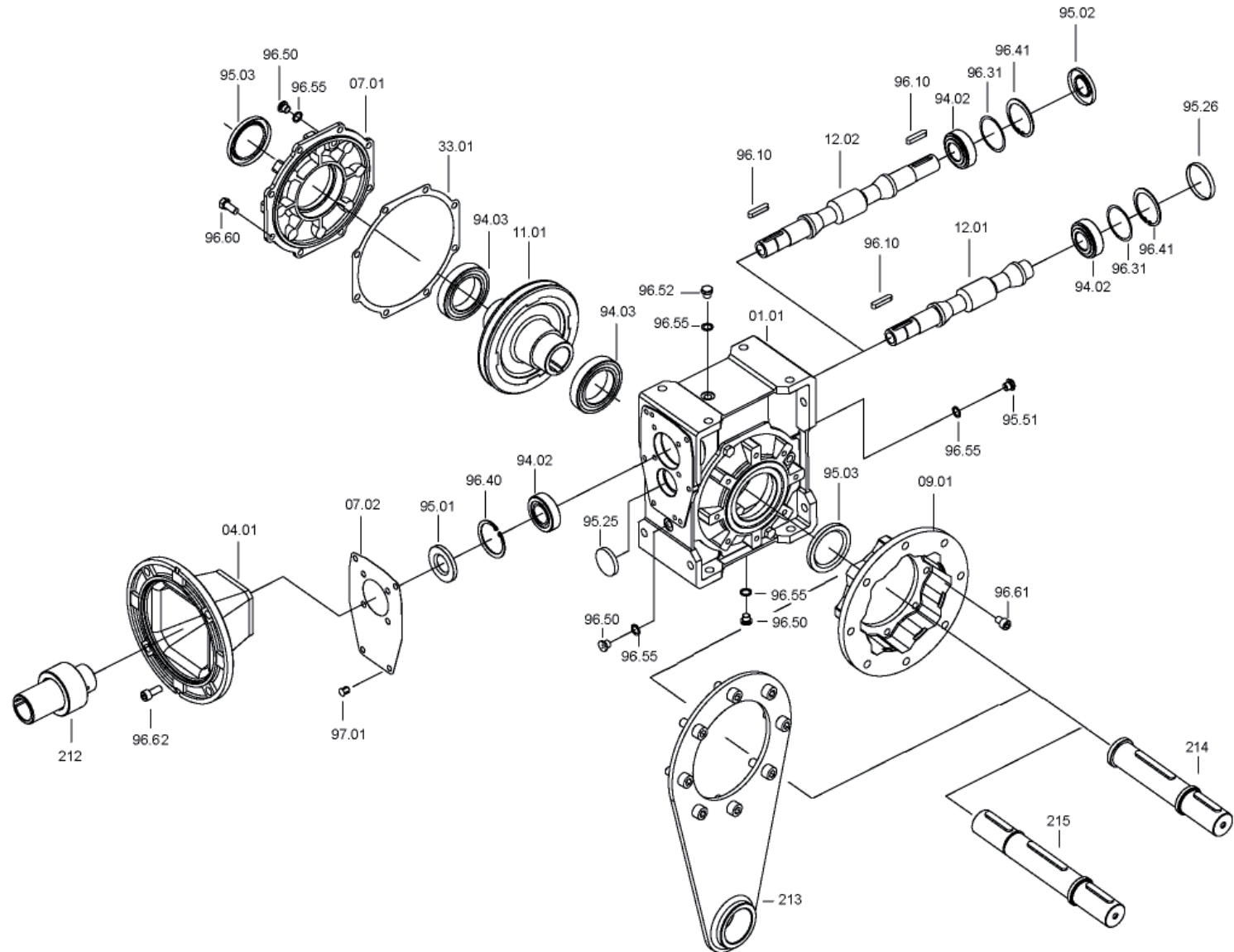



X	Cuscinetti / Bearings / Lager		Anelli di tenuta / Oilseals / Öldichtungen		
	XA - XF		XA - XF	XC-XF-XA	
	94.02	94.03	95.01	95.02	95.03
<b>30</b>	<b>6000</b> 10x26x8	<b>6005</b> 25x47x12	10/26/5.5	10/26/5.5	25/40/7
<b>40</b>	<b>6201</b> 12x32x10	<b>6006</b> 30x55x13	12/32/7	12/32/7	30/47/7
<b>50</b>	<b>6203</b> 17x40x12	<b>6008</b> 40x68x15	17/40/7	17/40/7	40/62/8
<b>63</b>	<b>30204</b> 20x47x15.25	<b>6008</b> 40x68x15	20/47/7	20/47/7	40/62/8
<b>75</b>	<b>30205</b> 25x52x16.25	<b>6010</b> 50x80x16	25/52/7	25/52/7	50/72/8
<b>90</b>	<b>32205</b> 25x52x19.25	<b>6010</b> 50x80x16	25/52/7	25/52/7	50/72/8
<b>110</b>	<b>32206B</b> 30x62x21.25	<b>6012</b> 60x95x18	30/62/7	30/62/7	60/85/8
<b>130</b>	<b>33208</b> 40x80x32	<b>6015</b> 75x115x20	40/80/10	40/80/10	75/100/10

Codice	Descrizione	Description	Beschreibung
01.01	Corpo	Housing	Gehaeuse
04.01	Campana	Bell	Glocke
07.01	Flangia pendolare	Side cover for shaft mounting	Flansch für Drehmomentstütze
07.02	Coperchio protezione entrata	Input safety cover	Schutzdeckel am Antrieb
09.01	Flangia uscita	Output flange	Abtriebsflansch
11.01	Corona uscita	Output wheel	Abtriebsrad
12.01	Vite senza fine	Worm shafts	Schneckenwelle
12.02	Vite senza fine bisporgente	Extended worm shaft	Doppelseitig herausragender
212	Giunto	Coupling	Kupplung
213	Kit braccio di reazione	Torque arm kit	Drehmomentstütze
214	Kit albero lento sporgente	Single output extended shaft kit	Abtriebswelle
215	Kit albero lento bisporgente	Double extended output shaft kit	Doppelvorstehende abtriebswelle
33.01	Guarnizione	Gasket	Dichtung

Codice	Descrizione	Description	Beschreibung
95.25	Cappellotto	Closed oilseal	Geschlossene oeldichtung
95.26	Cappellotto	Closed oilseal	Geschlossene oeldichtung
96.10	Linguetta	Key	Keil
96.31	Rasamento	Shim adjustment	Ausgleichscheibe
96.40	Seeger	Circlip	Seeger
96.41	Seeger	Circlip	Seeger
96.50	Tappo	Plug	Schraube
96.51	Tappo livello olio	Level plug	Oelstandschraube
96.52	Tappo di sfiato	Breather plug	Entlüftungsschraube
96.55	Rondella	Washer	Federring
96.60	Vite fissaggio	Tightening screw	Befestigungsschraube
96.61	Vite fissaggio	Tightening screw	Befestigungsschraube
96.62	Vite fissaggio	Tightening screw	Befestigungsschraube
97.01	Vite fissaggio	Tightening screw	Befestigungsschraube

# XC

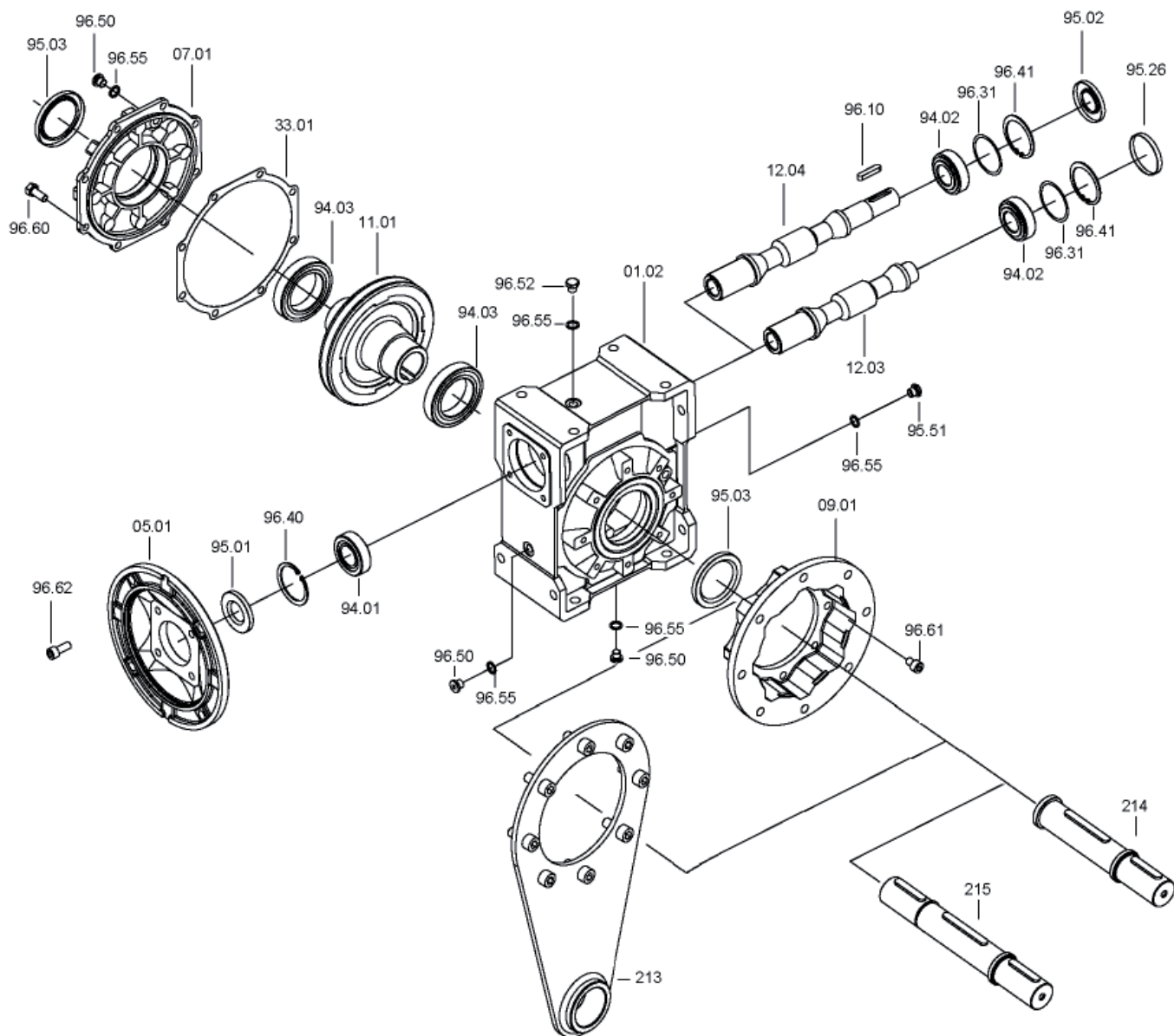

X	IEC	Cuscinetti / Bearings / Lager			Anelli di tenuta / Oilseals / Öldichtungen		
		XC			XC		
		94.01	94.02	94.03	95.01	95.02	95.03
30	56	61804 20x32x7	6000 10x26x8	6005 25x47x12	20/32/5	10/26/5.5	25/40/7
	63	61804 20x32x7			20/32/5		
40	56	6303 17x47x14	6201 12x32x10	6006 30x55x13	17/47/7	12/32/7	30/47/7
	63	6204 20x47x14			20/47/7		
	71	6005 25x47x12			25/47/7		
50	63	6204 20x47x14	6203 17x40x12	6008 40x68x15	20/47/7	17/40/7	40/62/8
	71	6005 25x47x12			25/47/7		
	80	6006 30x55x13			30/55/7		
63	71	30305 25x62x18.25	30204 20x47x15.25	6008 40x68x15	25/62/7	20/47/7	40/62/8
	80	30206 30x62x17.25			30/62/7		
	90	32007 35x62x18			35/62/7		
75	80	30206 30x62x17.25	30205 25x52x16.25	6010 50x80x16	30/62/7	25/52/7	50/72/8
	90	32007 35x62x18			35/62/7		
	100/112	32008 40x68x19			40/68/10		
90	80	30206 30x62x17.25	32205 25x52x19.25	6010 50x80x16	30/62/7	25/52/7	50/72/8
	90	32007 35x62x18			35/62/7		
	100/112	32008 40x68x19			40/68/10		
110	90	30208 40x80x19.75	32206B 30x62x21.25	6012 60x95x18	40/80/10	30/62/7	60/85/8
	100/112	30208 40x80x19.75			40/80/10		
	132	32010 50x80x20			50/80/10		
130	90	30208 40x80x19.75	33208 40x80x32	6015 75x115x20	40/80/10	40/80/10	75/100/10
	100/112	30208 40x80x19.75			40/80/10		
	132	32010 50x80x20			50/80/10		

Codice	Descrizione	Description	Beschreibung
01.02	Corpo	Housing	Gehäuse
05.01	Flangia	Flange	Flansch
07.01	Flangia pendolare	Side cover for shaft mounting	Flansch für Drehmomentstütze
09.01	Flangia uscita	Output flange	Abtriebsflansch
11.01	Corona uscita	Output wheel	Abtriebsrad
12.03	Vite senza fine PAM	Worm shafts IEC-input	Schneckenwelle IEC-antrieb
12.04	Vite senza fine PAM bisp.	Extended worm shafts IEC-input	Doppelseitig herausragender IEC-antrieb
213	Kit braccio di reazione	Torque arm kit	Drehmomentstütze
214	Kit albero lento sporgente	Single output extended shaft kit	Abtriebswelle
215	Kit albero lento bisporgente	Double extended output shaft kit	Doppelvorstehende abtriebswelle
33.01	Guarnizione	Gasket	Dichtung
95.26	Cappello	Closed oilseal	Geschlossene oeldichtung
96.10	Linguetta	Key	Keil
96.31	Rasamento	Shim adjustment	Ausgleichscheibe
96.40	Seeger	Circlip	Seeger
96.41	Seeger	Circlip	Seeger
96.50	Tappo	Plug	Schraube
96.51	Tappo livello olio	Level plug	Oelstandschrabe
96.52	Tappo di sfiato	Breather plug	Entlüftungsschraube
96.55	Rondella	Washer	Federring
96.60	Vite fissaggio	Tightening screw	Befestigungsschraube
96.61	Vite fissaggio	Tightening screw	Befestigungsschraube
96.62	Vite fissaggio	Tightening screw	Befestigungsschraube

# KC

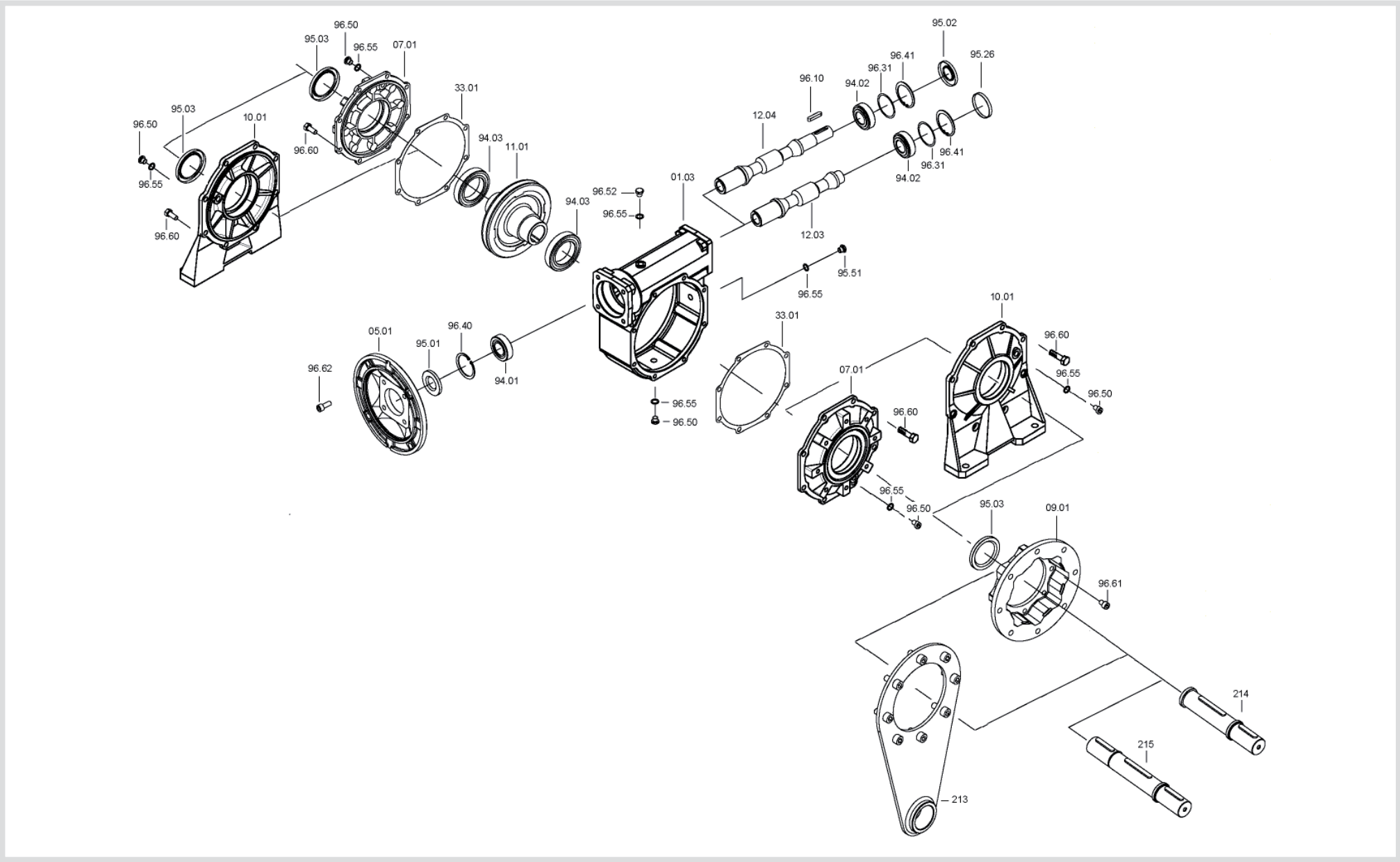

K	IEC	Cuscinetti / Bearings / Lager			Anelli di tenuta / Oilseals / Öldichtungen		
		XC			XC		
		94.01	94.02	94.03	95.01	95.02	95.03
30	56	61804 20x32x7	6000 10x26x8	6005 25x47x12	20/32/5	10/26/5.5	25/40/7
	63	61804 20x32x7			20/32/5		
40	56	6303 17x47x14	6201 12x32x10	6006 30x55x13	17/47/7	12/32/7	30/47/7
	63	6204 20x47x14			20/47/7		
	71	6005 25x47x12			25/47/7		
50	63	6204 20x47x14	6203 17x40x12	6008 40x68x15	20/47/7	17/40/7	40/62/8
	71	6005 25x47x12			25/47/7		
	80	6006 30x55x13			30/55/7		
63	71	30305 25x62x18.25	30204 20x47x15.25	6008 40x68x15	25/62/7	20/47/7	40/62/8
	80	30206 30x62x17.25			30/62/7		
	90	32007 35x62x18			35/62/7		
75	80	30206 30x62x17.25	32005 25x52x16.25	6010 50x80x16	30/62/7	25/52/7	50/72/8
	90	32007 35x62x18			35/62/7		
	100/112	32008 40x68x19			40/68/10		
90	80	30206 30x62x17.25	32205 25x52x19.25	6010 50x80x16	30/62/7	25/52/7	50/72/8
	90	32007 35x62x18			35/62/7		
	100/112	32008 40x68x19			40/68/10		
110	90	30208 40x80x19.75	32206B 30x62x21.25	6012 60x95x18	40/80/10	30/62/7	60/85/8
	100/112	30208 40x80x19.75			40/80/10		
	132	32010 50x80x20			50/80/10		
130	90	30208 40x80x19.75	33208 40x80x32	6015 75x115x20	40/80/10	40/80/10	75/100/10
	100/112	30208 40x80x19.75			40/80/10		
	132	32010 50x80x20			50/80/10		

Codice	Descrizione	Description	Beschreibung
01.03	Corpo	Housing	Gehäuse
05.01	Flangia	Flange	Flansch
07.01	Flangia pendolare	Side cover for shaft mounting	Flansch für Drehmomentstütze
09.01	Flangia uscita	Output flange	Abtriebsflansch
10.01	Piede	Foot	Fuß
11.01	Corona uscita	Output wheel	Abtriebsrad
12.03	Vite senza fine PAM	Worm shafts IEC-input	Schneckenwelle IEC-antrieb
12.04	Vite senza fine PAM bisp.	Extended worm shafts IEC-input	Doppelseitig herausragender IEC-antrieb
213	Kit braccio di reazione	Torque arm kit	Drehmomentstütze
214	Kit albero lento sporgente	Single output extended shaft kit	Abtriebswelle
215	Kit albero lento bisporgente	Double extended output shaft kit	Doppelvorstehende abtriebswelle
33.01	Guarnizione	Gasket	Dichtung
95.26	Cappello	Closed oilseal	Geschlossene oeldichtung
96.10	Linguetta	Key	Keil
96.31	Rasamento	Shim adjustment	Ausgleichscheibe
96.40	Seeger	Circlip	Seeger
96.41	Seeger	Circlip	Seeger
96.50	Tappo	Plug	Schraube
96.51	Tappo livello olio	Level plug	Ölstandschrabe
96.52	Tappo di sfianto	Breather plug	Entlüftungsschraube
96.55	Rondella	Washer	Federring
96.60	Vite fissaggio	Tightening screw	Befestigungsschraube
96.61	Vite fissaggio	Tightening screw	Befestigungsschraube
96.62	Vite fissaggio	Tightening screw	Befestigungsschraube

# HA - HF

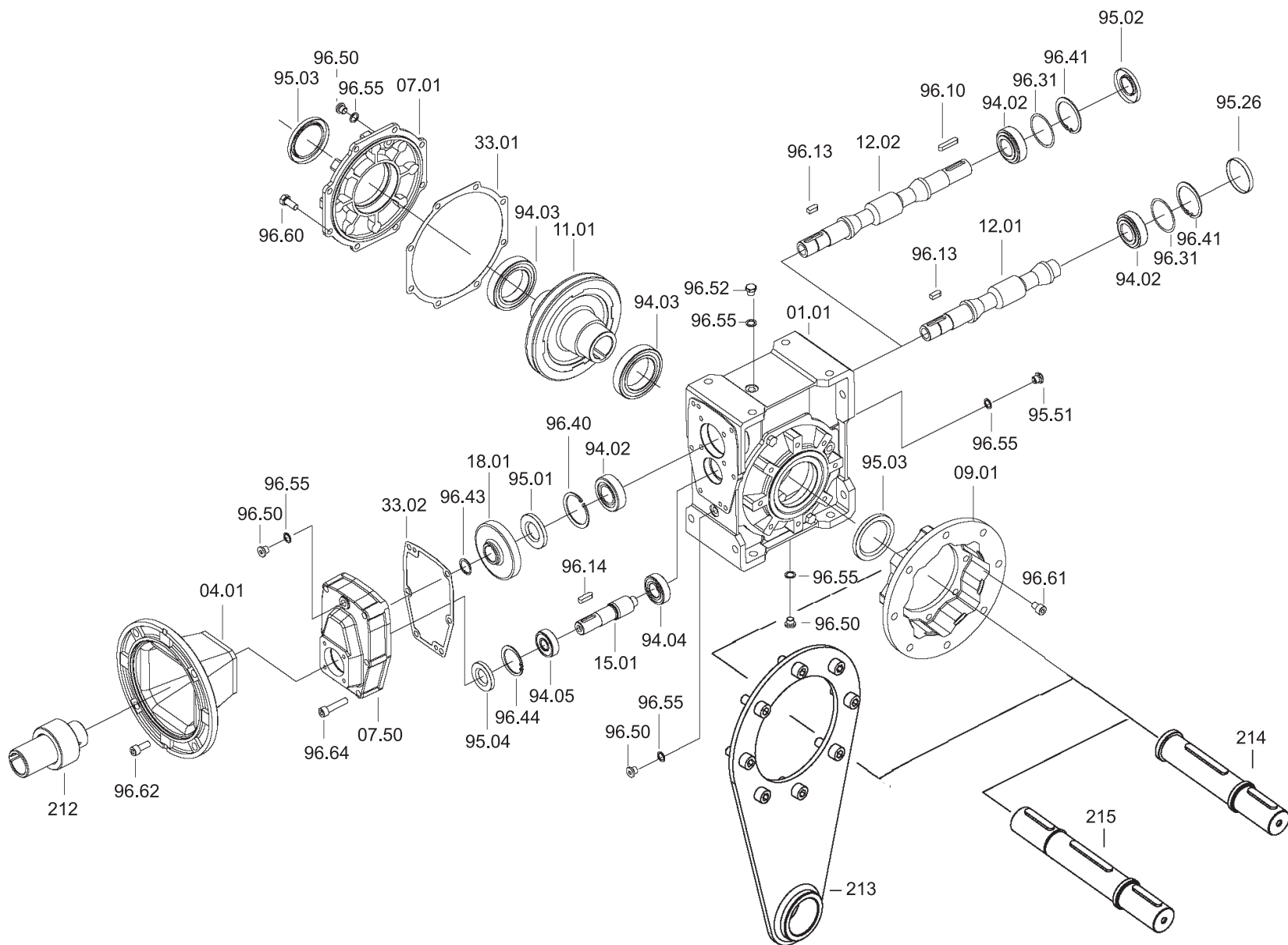



H	Cuscinetti / Bearings / Lager				Anelli di tenuta / Oilseals / Öldichtungen			
	HF - HA				HF - HA			
	94.02	94.03	94.04	94.05	95.01	95.02	95.03	95.04
<b>40</b>	<b>6201</b> 12x32x10	<b>6006</b> 30x55x13	<b>6000</b> 10x26x8	<b>6000</b> 10x26x8	12/32/7	12/32/7	30/47/7	10/26/5.5
<b>50</b>	<b>6203</b> 17x40x12	<b>6008</b> 40x68x15	<b>6200</b> 10x30x9	<b>6201</b> 12x32x10	17/40/7	17/40/7	40/62/8	12/32/7
<b>63</b>	<b>30204</b> 20x47x15.25	<b>6008</b> 40x68x15	<b>6203</b> 17x40x12	<b>6201</b> 12x32x10	20/47/7	20/47/7	40/62/8	17/40/7
<b>75</b>	<b>30205</b> 25x52x16.25	<b>6010</b> 50x80x16	<b>6202</b> 15x35x11	<b>6204</b> 20x47x14	25/52/7	25/52/7	50/72/8	20/47/7
<b>90</b>	<b>32205</b> 25x52x19.25	<b>6010</b> 50x80x16	<b>6202</b> 15x35x11	<b>6204</b> 20x47x14	25/52/7	25/52/7	50/72/8	20/47/7
<b>110</b>	<b>32206B</b> 30x62x21.25	<b>6012</b> 60x95x18	<b>6303</b> 17x47x14	<b>6205</b> 25x52x15	30/62/7	30/62/7	60/85/8	25/52/7
<b>130</b>	<b>33208</b> 40x80x32	<b>6015</b> 75x115x20	<b>6304</b> 20x52x15	<b>6305</b> 25x62x17	40/80/10	40/80/10	75/100/10	25/62/8

Codice	Descrizione	Description	Beschreibung
01.01	Corpo	Housing	Gehaeuse
04.01	Campana	Bell	Glocke
07.01	Flangia pendolare	Side cover for shaft mounting	Flansch für Drehmomentstutze
07.50	Corpo precoppia	Primary red. Housing	Vorstufe Gehaeuse
09.01	Flangia uscita	Output flange	Abtriebsflansch
11.01	Corona uscita	Output wheel	Abtriebsrad
12.01	Vite senza fine	Worm shafts	Schneckenwelle
12.02	Vite senza fine bisporgente	Extended worm shaft	Doppelseitig herausragender
15.01	Pignone cilindrico	Cylindrical pinion	Zyl.ritzel
18.01	Corona cilindrata	Cyl. wheel	Zyl.rad
212	Giunto	Coupling	Kupplung
213	Kit braccio di reazione	Torque arm kit	Drehmomentstütze
214	Kit albero lento sporgente	Single output extended shaft kit	Abtriebswelle
215	Kit albero lento bisporgente	Double extended output shaft kit	Doppelvorstehende abtriebswelle
31.01	Rondella	Washer	Federring
33.01	Guarnizione	Gasket	Dichtung
33.02	Guarnizione	Gasket	Dichtung
95.26	Cappellotto	Closed oilseal	Geschlossene oeldichtung

Codice	Descrizione	Description	Beschreibung
96.10	Linguetta	Key	Keil
96.13	Linguetta	Key	Keil
96.14	Linguetta	Key	Keil
96.31	Rasamento	Shim adjustment	Ausgleichscheibe
96.40	Seeger	Circlip	Seeger
96.41	Seeger	Circlip	Seeger
96.43	Seeger	Circlip	Seeger
96.44	Seeger	Circlip	Seeger
96.50	Tappo	Plug	Schraube
96.51	Tappo livello olio	Level plug	Oelstandschrabe
96.52	Tappo di sfianto	Breather plug	Entlueftungsschraube
96.55	Rondella	Washer	Federring
96.60	Vite fissaggio	Tightening screw	Befestigungsschraube
96.61	Vite fissaggio	Tightening screw	Befestigungsschraube
96.62	Vite fissaggio	Tightening screw	Befestigungsschraube
96.64	Vite fissaggio	Tightening screw	Befestigungsschraube

**KXC - XXC - XXA - XXF - KKC**

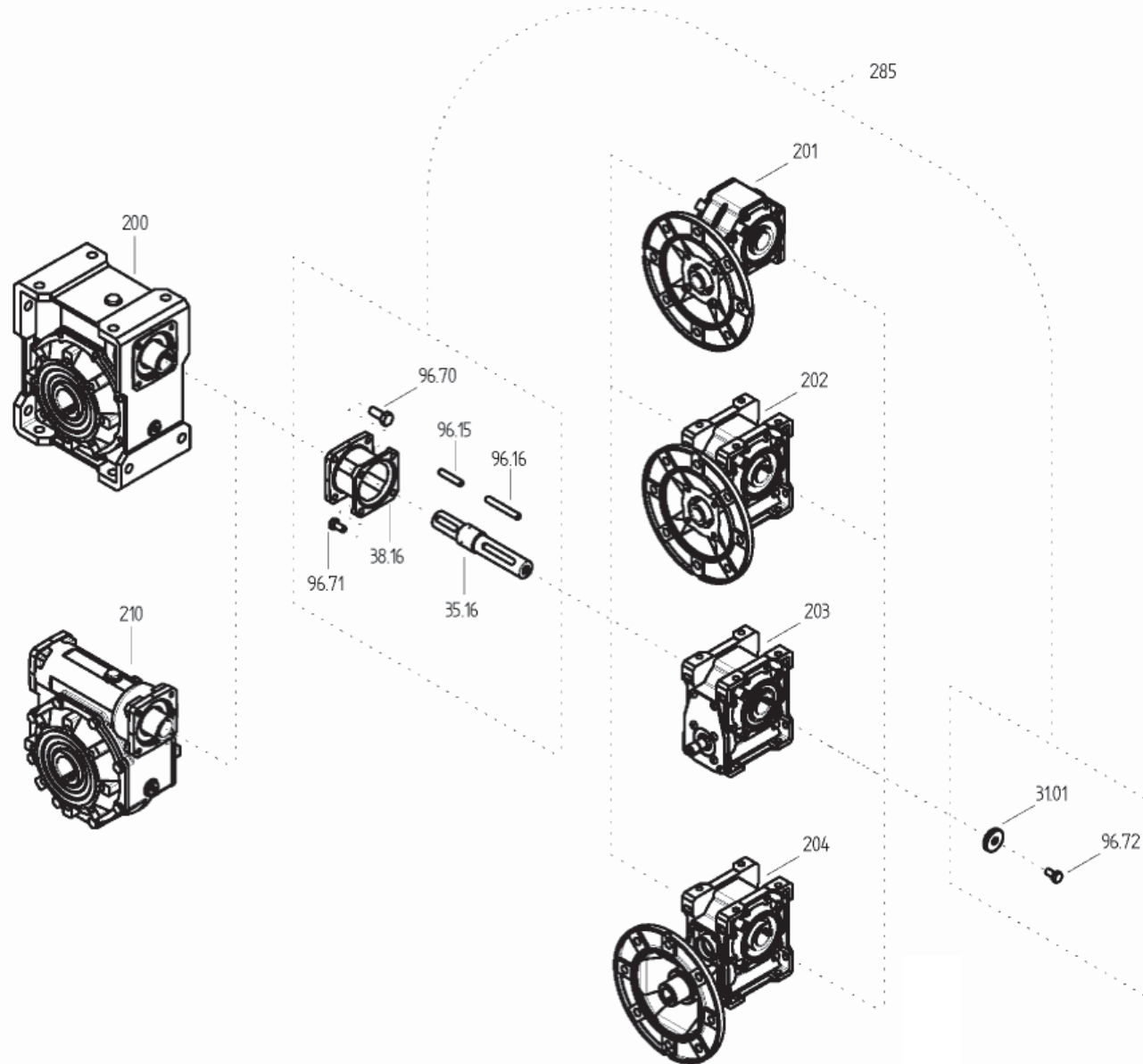



KX.. XX.. KK	Combinato / <i>Combined</i> / Kombiniert		Combinato compatto / <i>Compact Combined Line</i> / Kombiniert -Kompakte Ausführung	
	Tondo-Quadro / <i>Round-Square</i> / Rund-Viereckig		Tondo-Tondo / <i>Round-Round</i> / Rund-Rund	
	KXC		KKC	
	Quadro-Quadro / <i>Square-Square</i> / Viereckig-Viereckig		XXC - XXA - XXF	
	IN	OUT	IN	OUT
<b>30/30</b>		X30 <b>NO/PAM/φ9</b>		K30 <b>NO/PAM/φ9</b>
<b>30/40</b>	KC30 XA30 XF30 XC30	X40 <b>NO/PAM/φ11</b>	KC30	K40 <b>NO/PAM/φ11</b>
<b>30/50</b>		X50 <b>NO/PAM/φ14</b>		K50 <b>NO/PAM/φ14</b>
<b>30/63</b>		X63 <b>NO/PAM/φ19</b>		K63 <b>NO/PAM/φ19</b>
<b>40/63</b>	KC40 XA40 XF40 XC40	X75 <b>NO/PAM/φ24</b>	KC40	K75 <b>NO/PAM/φ24</b>
<b>40/75</b>		X90 <b>NO/PAM/φ24</b>		K90 <b>NO/PAM/φ24</b>
<b>40/90</b>		X75 <b>NO/PAM/φ24</b>		K75 <b>NO/PAM/φ24</b>
<b>50/75</b>	KC50 XA50 XF50 XC50	X90 <b>NO/PAM/φ24</b>	KC50	K90 <b>NO/PAM/φ24</b>
<b>50/90</b>		X110 <b>NO/PAM/φ28</b>		KC63
<b>50/110</b>				
<b>63/110</b>	KC63 XA63 XF63 XC63	X130 <b>NO/PAM/φ28</b>	KC63	K130 <b>NO/PAM/φ28</b>
<b>63/130</b>				

Codice	Descrizione	Description	Beschreibung
200	Riduttore serie X NO/PAM	<i>Gearbox X series NO/IEC</i>	Getriebe Serie X NEIN/IEC
201	Riduttore serie KC	<i>Gearbox KC series</i>	Getriebe Serie KC
202	Riduttore serie XC	<i>Gearbox XC series</i>	Getriebe Serie XC
203	Riduttore serie XA	<i>Gearbox XA series</i>	Getriebe Serie XA
204	Riduttore serie XF	<i>Gearbox XF series</i>	Getriebe Serie XF
210	Riduttore serie K NO/PAM	<i>Gearbox K series NO/IEC</i>	Getriebe Serie K NEIN/IEC
285	Kit combinazione	<i>Combined Kit</i>	Kombinationsvorrichtung

Codice	Descrizione	Description	Beschreibung
31.01	Rondella	<i>Washer</i>	Scheibe
35.16	Albero di combinazione	<i>Combined shaft</i>	Kombinationswelle
38.16	Flangia di combinazione	<i>Combined Flange</i>	Kombinationsflansch
96.15	Linguetta	<i>Key</i>	Keil
96.16	Linguetta	<i>Key</i>	Keil
96.70	Vite fissaggio	<i>Tightening screw</i>	Befestigungsschraube
96.71	Vite fissaggio	<i>Tightening screw</i>	Befestigungsschraube
96.72	Vite fissaggio	<i>Tightening screw</i>	Befestigungsschraube

**XA - XF - XC - KC - HA - HF - XXA - XXF - XXC - KXC - KKC**

Dispositivo limitatore di coppia - *Torque limiter device* - Rutschkupplungsvorrichtung

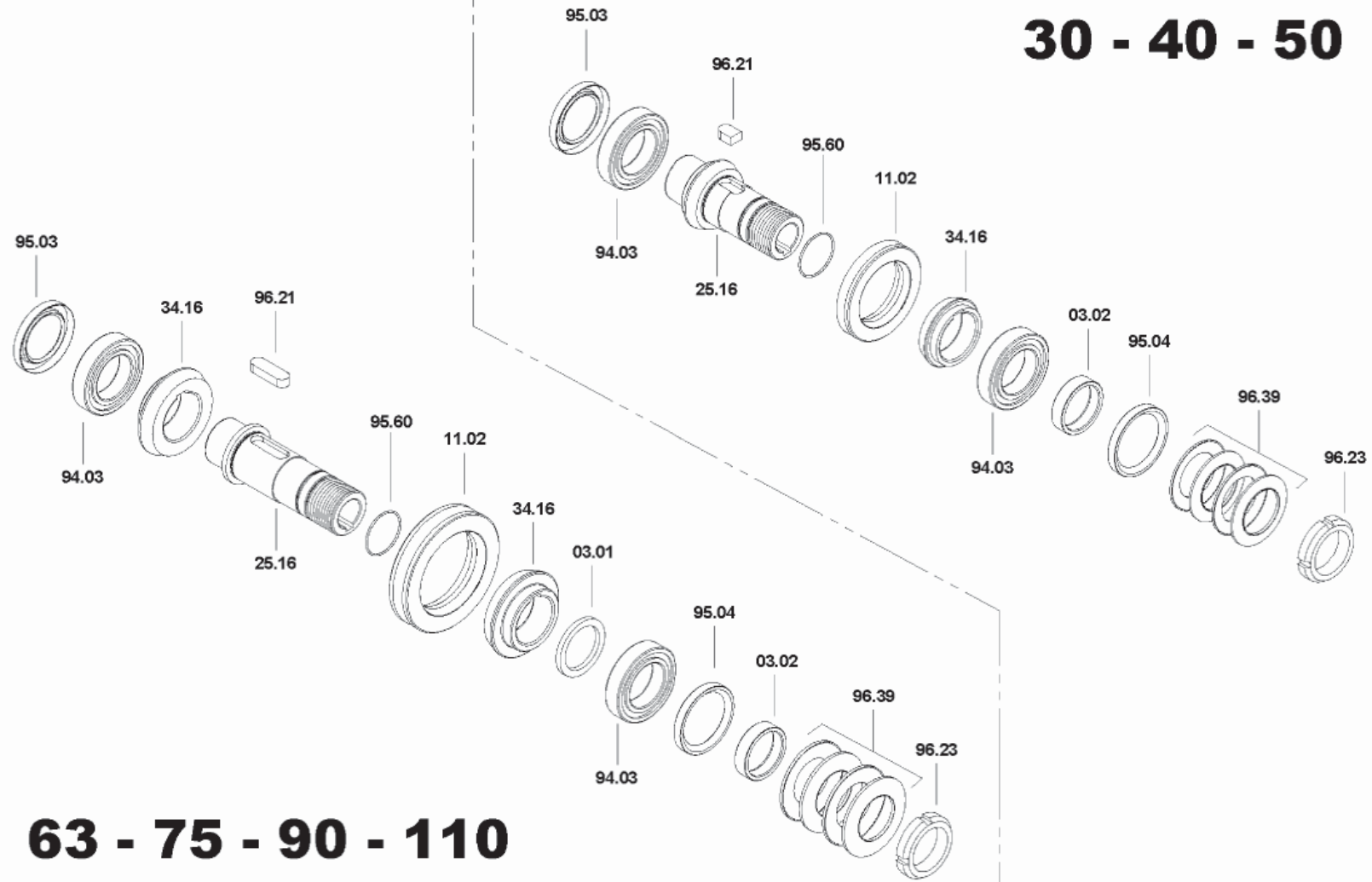



LD - LS		Cuscinetti / Bearings / Lager	Anelli di tenuta / Oilseals / Öldichtungen		Particolari Commerciali / Market - items / Markt - Teile			Molle a Tazza / Washers / Feder	
X - H - K	XX.. - KX.. - KK..	Cus. Sfere	BASL	BASL	O ring	Linguetta / Key / Keil	Ghiera / Ring Nut / Nutmutter	X - H - K	XX.. - KX.. - KK
		<b>94.03</b>	<b>95.03</b>	<b>95.04</b>	<b>95.60</b>	<b>96.21</b>	<b>96.23</b>	<b>96.39</b>	
<b>30</b>	<b>30/30</b>	<b>6005</b> 25x47x12	25/40/7	30/40/5	<b>2087</b> 21.95x1.78	8x7x10 AB	M25x1.5	50x25.4x1.25	50x25.4x1.5
<b>40</b>	<b>30/40</b>	<b>6006</b> 30x55x13	30/47/7	35/47/7	<b>2106</b> 26.70x1.78	10x8x13 AB	M30x1.5	56x30.5x1.8	56x30.5x2.0
<b>50</b>	<b>30/50</b>	<b>6008</b> 40x68x15	40/62/8	48/62/8	36.27x1.78	12x8x18 AB	M40x1.5	63x40.5x1.8	63x40.5x2.5
<b>63</b>	<b>30/63 - 40/63</b>	<b>6008</b> 40x68x15	40/62/8	48/62/8	36.27x1.78	12x8x40 A	M40x1.5	71x40.5x2.0	71x40.5x2.5
<b>75</b>	<b>40/75 - 50/75</b>	<b>6010</b> 50x80x16	50/72/8	58/72/8	<b>2187</b> 47.37x1.78	16x10x40 A	M50x1.5	90x50.5x2.5	90x50.5x3.5
<b>90</b>	<b>40/90 - 50/90</b>	<b>6010</b> 50x80x16	50/72/8	58/72/8	<b>2187</b> 47.37x1.78	16x10x50 A	M50x1.5	100x51.x2.7	100x51x3.5
<b>110</b>	<b>50/110 - 63/110</b>	<b>6012</b> 60x95x18	60/85/8	70/85/8	<b>2225</b> 56.87x1.78	18x11x60 A	M60x2.0	125x61x4.0	125x61x5.0
<b>130</b>	<b>63/130</b>								

Codice	Descrizione	Description	Beschreibung
03.01	Distanziale	Spacer	Abstandsstück
03.02	Distanziale molle	Washers Spacer	Feder - Abstandsstück
11.02	Corona limitatore	Ring Gear for Torque Limiter	Drehmomentbegrenzer - Rad
25.16	Albero cavo limitatore	Hollow shaft of torque Limiter	Drehmomentbegrenzer - Hohlwelle
34.16	Cono di frizione	Cone clutch	Einreibungskegel

Codice	Descrizione	Description	Beschreibung
94.03	Cuscinetto	Bearing	Lager
95.03	Paraolio NBR	Oilseal	Öldichtungen
95.04	Paraolio NBR	Oilseal	Öldichtungen
95.60	OR NBR	O - Ring	O - Ring
96.21	Linguetta	Key	Keil
96.23	Ghiera Autobloccante	Self - locking ring nut	Selbstsperrende Nutmutter
96.39	4 Molle a Tazza in serie	4 Belleville washers in series	4 Serienanordnung Tellerfeder



## 8.0 CONDIZIONI GENERALI DI GARANZIA

La garanzia relativa a difetti di costruzione ha la durata di un anno dalla data di fatturazione delle merci. Tale garanzia comporta per la TRAMEC l'onere della sostituzione o riparazione delle parti difettose ma non ammette ulteriore addebito per eventuali danni diretti o indiretti di qualsiasi natura. La garanzia decade nel caso in cui non siano state osservate le disposizioni riportate nel medesimo manuale di uso e manutenzione e/o siano state eseguite riparazioni o apportate modifiche senza nostro consenso scritto.

**La merce di ritorno sarà da noi accettata solo se spedita franco di ogni spesa.**

## 8.0 GENERAL CODITIONAL OF WARRANTY

*Warranty for manufacturing defects will expire one-year the invoicing date. TRAMEC will replace or repair defective parts but will not accept any further charges for direct or indirect damages of any kind. The warranty will become null and void if the instructions given in the use and maintenance manual are not complied with or if repairs or changes are carried out without our prior written authorization.*

***Returned goods will be accepted only if delivered free of any charge.***

## 8.0 ALLGEMEINE GARANTIEBEDINGUNGEN

Die Garantie auf Herstellungsfehler dauert ein Jahr ab Rechnungsdatum der Ware. Aufgrund Garantie unterliegt der TRAMEC die Pflicht der Ersetzung oder Reparatur der defekten Teile, jedoch nicht die Übernahme weiterer Belastungen für direkte oder indirekte Schäden egal welcher Natur. Die Garantie verfällt bei Nichtbeachtung der in der betreffenden "Betriebs- und Instandhaltungsanleitung" angeführten Anweisungen und/oder falls ohne unsere vorausgehende schriftliche Genehmigung Reparaturen oder Änderungen vorgenommen wurden.

**Die an uns zurückgesendete Ware akzeptieren wir nur wenn gebührenfrei geliefert.**