

B5

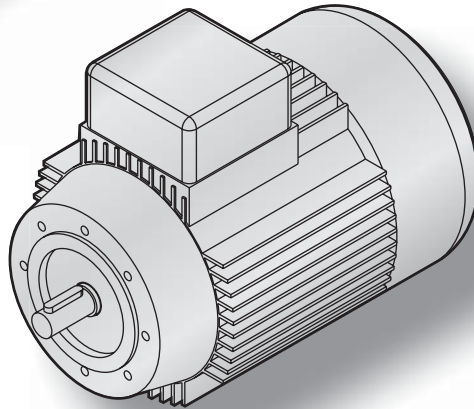

B14

B5

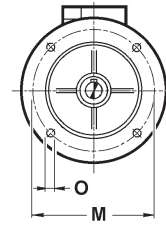
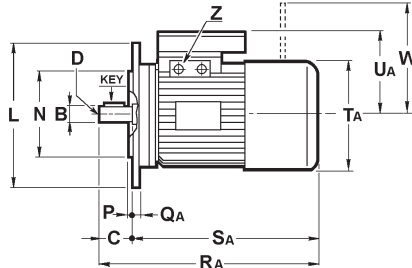
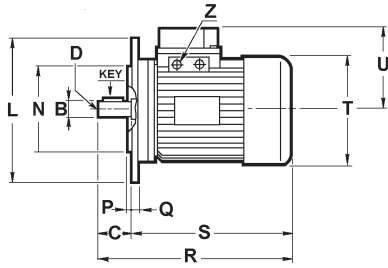

Motori elettrici ⁽¹⁾
Electric motors
Elektromotoren

Motori elettrici autofrenanti ⁽²⁾
Electric brake motors
Elektro-Bremsmotoren

	4 poles	kW	kg. (1)	kg. (2)	B	C	D	L	M	N	O	P	Q	QA	R	RA	S	SA	T	TA	U	UA	W	Z	KEY
56	A	0.06	2.5	4	9	20	M4	120	100	80	7	3	8	8	188	220	168	200	110	110	108	108	90	PG11	3x3x15
	B	0.09	2.6	5																				PG11	3x3x15
	C	0.11	3.2	5																				PG11	3x3x15
63	A	0.13	3.7	5	11	23	M4	140	115	95	9	3	9	9	208	257	185	234	123	123	110	110	98	PG11	4x4x15
	B	0.18	4.3	7																				PG11	
	C	0.22	4.3	7																				PG11	
71	A	0.25	5.8	8	14	30	M5	160	130	110	9	3.5	9	9	245	297	215	267	140	140	121	121	98	PG11	5x5x20
	B	0.37	6.2	8																				PG11	
	C	0.55	7.4	9																				PG11	
80	A	0.55	8.5	11	19	40	M6	200	165	130	11	3.5	10	10	278	336	238	296	159	159	138	138	111	PG16	6x6x30
	B	0.75	9.8	13																				PG16	
	C	0.9	10.5	13.5																				PG16	
90	S	1.1	12	17	24	50	M8	200	165	130	11	3.5	10	10	305	369	255	319	176	176	149	149	129	PG16	8x7x35
	L	1.5	13.5	18											330	394	280	344						PG16	
	LB	1.8	15.5	20											PG16										
100	A	2.2	19	25.5	28	60	M10	250	215	180	14	4	14	14	369	434	309	374	195	195	160	160	139	PG16	8x7x45
	B	3	21	28																				PG16	
	BL	4	23	30																				PG16	
112	A	4	29	38	28	60	M10	250	215	180	14	4	14	14	388	467	328	407	219	219	172	172	161	PG16	8x7x45
	BL	5.5	35	44																				PG16	
	S	5.5	43	56																				448	
M	7.5	52	66	485	600	405	520	PG21																	
ML	9.2	54	68	PG21																					
160	M	11	96	42	110	M16	350	300	250	18	5	15	15	610	805	500	695	320	330	245	245	1" G	12x8x90		
	L	15	109											654	860	544	750								
180	M	18.5	121	48	110	M16	350	300	250	19	5	15	15	697	880	587	770	360	370	275	275	1" G	14x9x90		
	L	22	151											735	920	625	810								
200	L	30	193	55	110	M16	400	350	300	19	5	15	15	800	1060	690	950	400	410	300	300	1"1/4 G	16x10x90		
225	S	37	313	60	140	M20	450	400	350	18	5	16		830		690		450		330		1"1/4 G	18x11x120		
	M	45	355											PG21											

Le dimensioni dei motori elettrici sono puramente indicative.

The dimensions of the electric motors are approximate values.

Die Abmessungen der Elektromotoren sind Näherungswerte.

B14

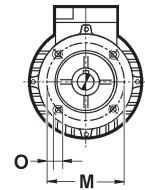
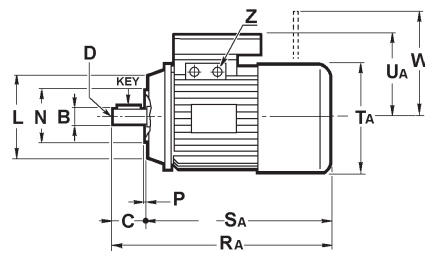
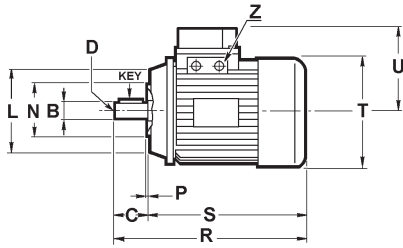

Motori elettrici ⁽¹⁾
Electric motors
Elektromotoren

Motori elettrici autofrenanti ⁽²⁾
Electric brake motors
Elektro-Bremsmotoren

	4 poles	kW	kg. (1)	kg. (2)	B	C	D	L	M	N	O	P	R	RA	S	SA	T	TA	U	UA	W	Z	KEY
56	A	0.06	2.5	4	9	20	M4	80	65	50	M5	2.5	188	220	168	200	110	110	108	108	90	PG11	3x3x15
	B	0.09	2.6	5																		PG11	3x3x15
	C	0.11	3.2	5																		PG11	3x3x15
63	A	0.13	3.7	5	11	23	M4	90	75	60	M5	2.5	208	257	185	234	123	123	110	110	98	PG11	4x4x15
	B	0.18	4.3	7																		PG11	
	C	0.22	4.3	7																		PG11	
71	A	0.25	5.8	8	14	30	M5	105	85	70	M6	2.5	245	297	215	267	140	140	121	121	98	PG11	5x5x20
	B	0.37	6.2	8																		PG11	
	C	0.55	7.4	9																		PG11	
80	A	0.55	8.5	11	19	40	M6	120	100	80	M6	3	278	336	238	296	158	159	138	138	111	PG16	6x6x30
	B	0.75	9.8	13																		PG16	
	C	0.9	10.5	13.5																		PG16	
90	S	1.1	12	17	24	50	M8	140	115	95	M8	3	305	369	255	319	176	176	149	149	129	PG16	8x7x35
	L	1.5	13.5	18									330	394	280	344							
	LB	1.8	15.5	20																			
100	A	2.2	19	25.5	28	60	M10	160	130	110	M8	3.5	369	434	309	374	195	195	173	160	139	PG16	8x7x45
	B	3	21	28																			
	BL	4	23	30																			
112	A	4	29	38	28	60	M10	160	130	110	M8	3.5	388	467	328	407	219	219	192	172	161	PG16	8x7x45
	BL	5.5	35	44																		PG16	
132	S	5.5	43	56	38	80	M12	200	165	130	M10	4	448	570	368	490	258	258	192	192	186	PG21	10x8x60
	M	7.5	52	66									485	600	405	520							
	ML	9.2	54	68																			

Le dimensioni dei motori elettrici sono puramente indicative.

The dimensions of the electric motors are approximate values.

Die Abmessungen der Elektromotoren sind Näherungswerte.